

Snubber MKP Capacitors for Pulse Applications with Double-Sided Metallized Electrodes and Internal Series Connection. Capacitances from 0.047 μF to 8.0 μF . Rated Voltages from 700 VDC to 3000 VDC.

Special Features

- Pulse duty construction
- Self-healing
- Particularly reliable contact-configurations: 4-pin versions and screwable plate connections
- Internal series connection
- Very low dissipation factor
- Negative capacitance change versus temperature
- AEC-Q200 qualified
- According to RoHS 2015/863/EU

Typical Applications

For high pulse and high frequency applications requiring extremely reliable contacts e.g.

- IGBT-applications

Construction

Dielectric:

Polypropylene (PP) film

Capacitor electrodes:

Double-sided metallized plastic film

Internal construction:

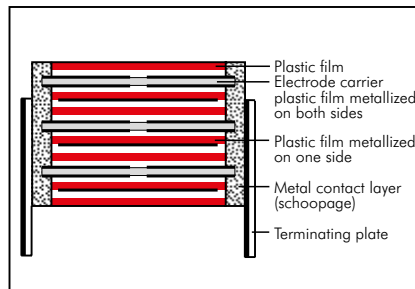

Encapsulation:

Solvent-resistant, flame-retardant plastic case with epoxy resin seal, UL 94 V-0

Terminations:

Tinned wire or plates.

Marking:

Colour: Red. Marking: Black.

Electrical Data

Capacitance range: 0.047 μF to 8.0 μF

Rated voltages: 700 VDC, 850 VDC, 1000 VDC, 1250 VDC, 1700 VDC, 2000 VDC, 2500 VDC, 3000 VDC

Capacitance tolerances: $\pm 20\%$, $\pm 10\%$, $\pm 5\%$ (other tolerances are available subject to special enquiry)

Operating temperature range: -55°C to $+105^\circ\text{C}$

Insulation resistance at $+20^\circ\text{C}$:

$C \leq 0.33 \mu\text{F}$: $\geq 1 \times 10^5 \text{ M}\Omega$

$C > 0.33 \mu\text{F}$: $\geq 30000 \text{ sec (M}\Omega \times \mu\text{F)}$

Measuring voltage: 100 V/1 min.

Test voltage: 2 sec

L	$\leq 2000 \text{ VDC}$	2500 VDC	$\geq 3000 \text{ VDC}$
< 41.5	$1.6 U_r$	$1.4 U_r$	$1.2 U_r$
41.5	$1.4 U_r$	$1.4 U_r$	$1.2 U_r$
56	$1.2 U_r$	$1.2 U_r$	$1.2 U_r$

Dissipation factors at $+20^\circ\text{C}$: $\tan \delta$

at f	$C \leq 0.1 \mu\text{F}$	$0.1 \mu\text{F} < C \leq 1.0 \mu\text{F}$	$C > 1.0 \mu\text{F}$
1 kHz	$\leq 6 \times 10^{-4}$	$\leq 6 \times 10^{-4}$	$\leq 6 \times 10^{-4}$
10 kHz	$\leq 6 \times 10^{-4}$	$\leq 6 \times 10^{-4}$	–
100 kHz	$\leq 15 \times 10^{-4}$	–	–

Climatic test category:

55/100/56 in accordance with IEC

Voltage derating:

A voltage derating factor of 1.35 % per K must be applied from $+85^\circ\text{C}$ for DC voltages and from $+75^\circ\text{C}$ for AC voltages

Reliability:

Operational life > 300000 hours

Failure rate < 1 fit ($0.5 \times U_r$ and 40°C)

Specific dissipation:

Box size* WxHxL in mm	Specific dissipation in Watts per K above the ambient temperature
19x31x56	0.068
23x34x56	0.079
27x37.5x56	0.092
33x48x56	0.122
37x54x56	0.142

* other box sizes see page 10.

Maximum pulse rise time:

Capacitance μF	max. pulse rise time V/ μsec at $T_A < 40^\circ\text{C}$							
	700VDC	850VDC	1000VDC	1250VDC	1700VDC	2000VDC	2500VDC	3000VDC
0.047 ... 0.22	1150	1150	1800	1800	1800	1800	1800	1800
0.33 ... 0.68	900	900	1150	1150	1150	1150	1150	1150
1.0 ... 2.2	500	500	500	500	650	650	650	650
2.5 ... 6.8	190	190	390	390	500	–	–	–
7.0 ... 8.0	90	90	–	–	–	–	–	–

Mounting Recommendation

Excessive mechanical strain, e.g. pressure or shock onto the capacitor body, is to be avoided during mounting and usage of the capacitors. When fixing the plates the screw torque is to be limited to max. 5 Nm.

For further details and graphs please refer to Technical Information.

Packing

Packing units at the end of the catalogue.

Packing quantities may vary depending on the plate version.

Continuation

General Data

Capacitance	700 VDC/420 VAC*				850 VDC/450 VAC*				1000 VDC/600 VAC*				
	W	H	L	Part number	W	H	L	Part number	W	H	L	Part number	
0.22 μ F										11	21	31.5	SNMPO132206B
										11	22	41.5	SNMPO132207B
0.33 "					15	26	31.5	SNMPM033306F		15	26	31.5	SNMPO133306F
					13	24	41.5	SNMPM033307C		13	24	41.5	SNMPO133307C
0.47 "	11	21	31.5	SNMPK034706B	17	29	31.5	SNMPM034706G		17	29	31.5	SNMPO134706G
	11	22	41.5	SNMPK034707B	15	26	41.5	SNMPM034707D		15	26	41.5	SNMPO134707D
0.68 "	15	26	31.5	SNMPK036806F	17	29	41.5	SNMPM036807E		17	29	41.5	SNMPO136807E
	13	24	41.5	SNMPK036807C									
1.0 μ F	17	29	31.5	SNMPK041006G	19	32	41.5	SNMPM041007F		20	39.5	41.5	SNMPO141007G
	15	26	41.5	SNMPK041007D						23	34	56	SNMPO141008E
1.5 "	19	32	41.5	SNMPK041507F	20	39.5	41.5	SNMPM041507G		24	45.5	41.5	SNMPO141507H
					23	34	56	SNMPM041508E		23	34	56	SNMPO141508E
2.0 "	20	39.5	41.5	SNMPK042007G	24	45.5	41.5	SNMPM042007H		31	46	41.5	SNMPO142007I
					23	34	56	SNMPM042008E		27	37.5	56	SNMPO142008H
2.2 "	20	39.5	41.5	SNMPK042207G	24	45.5	41.5	SNMPM042207H		31	46	41.5	SNMPO142207I
					23	34	56	SNMPM042208E		27	37.5	56	SNMPO142208H
2.5 "	24	45.5	41.5	SNMPK042507H	31	46	41.5	SNMPM042507I		35	50	41.5	SNMPO142507J
					27	37.5	56	SNMPM042508H		33	48	56	SNMPO142508J
3.0 "	24	45.5	41.5	SNMPK043007H	31	46	41.5	SNMPM043007I		40	55	41.5	SNMPO143007K
					27	37.5	56	SNMPM043008H		33	48	56	SNMPO143008J
3.3 "	24	45.5	41.5	SNMPK043307H	35	50	41.5	SNMPM043307J		40	55	41.5	SNMPO143307K
					33	48	56	SNMPM043308J		33	48	56	SNMPO143308J
4.0 "	31	46	41.5	SNMPK044007I	35	50	41.5	SNMPM044007J		37	54	56	SNMPO144008L
					33	48	56	SNMPM044008J					
4.7 "	31	46	41.5	SNMPK044707I	33	48	56	SNMPM044708J		37	54	56	SNMPO144708L
5.0 "	31	46	41.5	SNMPK045007I	33	48	56	SNMPM045008J		37	54	56	SNMPO145008L
6.0 "	35	50	41.5	SNMPK046007J	37	54	56	SNMPM046008L		37	54	56	SNMPO146008L
	33	48	56	SNMPK046008J									
7.0 "	40	55	41.5	SNMPK047007K	37	54	56	SNMPM047008L					
	33	48	56	SNMPK047008J									
8.0 "	37	54	56	SNMPK048008L									

* AC voltages: $f \leq 1000$ Hz; $1.4 \times U_{rms} + UDC \leq U_r$

Dims. in mm.

Ionisation inception level in isolated cases may be lower than admissible rated AC voltage.

Versions and dimensional drawings see page 96.

Part number completion:

Version codes see page 98.

Tolerance: 20 % = M

10 % = K

5 % = J

Packing: bulk = S

Pin length: 6-2 = SD

none = 00 (for plate versions)

Rights reserved to amend design data without prior notification.

Continuation page 88

Continuation

General Data

Capacitance	1250 VDC/600 VAC*				1700 VDC/650 VAC*				2000 VDC/700 VAC*			
	W	H	L	Part number	W	H	L	Part number	W	H	L	Part number
0.068 µF									11	21	31.5	SNMPTA31006B
									11	22	41.5	SNMPTA31007B
0.1 µF					11	21	31.5	SNMPTA31006B	13	24	31.5	SNMPTA31006D
0.15 "					11	22	41.5	SNMPTA31007B	11	22	41.5	SNMPTA31007B
					13	24	31.5	SNMPTA31506D	15	26	31.5	SNMPTA31506F
0.22 "	11	21	31.5	SNMPTA31507B	11	22	41.5	SNMPTA31507B	13	24	41.5	SNMPTA31507C
	11	22	41.5	SNMPTA32206B	15	26	31.5	SNMPTA32206F	15	26	41.5	SNMPTA32207D
0.33 "	13	24	31.5	SNMPTA32207C	13	24	41.5	SNMPTA32207C				
	15	26	31.5	SNMPTA33306F	17	34.5	31.5	SNMPTA33306I	19	32	41.5	SNMPTA33307F
0.47 "	13	24	41.5	SNMPTA33307D	15	26	41.5	SNMPTA33307D				
	17	29	31.5	SNMPTA34707F	19	32	41.5	SNMPTA34707F	20	39.5	41.5	SNMPTA34707G
0.68 "	15	26	41.5	SNMPTA36807G					23	34	56	SNMPTA36807E
	17	29	41.5	SNMPTA36807E	20	39.5	41.5	SNMPTA36807G	24	45.5	41.5	SNMPTA36807H
				23	34	56	SNMPTA36808E	27	37.5	56	SNMPTA36808H	
1.0 µF	20	39.5	41.5	SNMPTA41007H	24	45.5	41.5	SNMPTA41007H	35	50	41.5	SNMPTA41007J
	23	34	56	SNMPTA41008H	27	37.5	56	SNMPTA41008H	33	48	56	SNMPTA41008J
1.5 "	24	45.5	41.5	SNMPTA41507I	31	46	41.5	SNMPTA41507I	40	55	41.5	SNMPTA41507K
	23	34	56	SNMPTA41508E	27	37.5	56	SNMPTA41508E	33	48	56	SNMPTA41508J
2.0 "	31	46	41.5	SNMPTA42007K	40	55	41.5	SNMPTA42007K	37	54	56	SNMPTA42008L
	27	37.5	56	SNMPTA42008J	33	48	56	SNMPTA42008J				
2.2 "	31	46	41.5	SNMPTA42207K	40	55	41.5	SNMPTA42207K	37	54	56	SNMPTA42208J
	27	37.5	56	SNMPTA42208J	33	48	56	SNMPTA42208J				
2.5 "	35	50	41.5	SNMPTA42507J	37	54	56	SNMPTA42508L				
	33	48	56	SNMPTA43007K								
3.0 "	40	55	41.5	SNMPTA43008J	37	54	56	SNMPTA43008L				
	33	48	56	SNMPTA43307K								
3.3 "	40	55	41.5	SNMPTA43308J								
	33	48	56	SNMPTA44008L								
4.0 "	37	54	56	SNMPTA44708L								
4.7 "	37	54	56	SNMPTA45008L								
5.0 "	37	54	56	SNMPTA46008L								
6.0 "	37	54	56									

* AC voltages: $f \leq 1000 \text{ Hz}$; $1.4 \times U_{\text{rms}} + \text{UDC} \leq U_r$

Dims. in mm.

Ionisation inception level in isolated cases may be lower than admissible rated AC voltage.

Versions and dimensional drawings see page 96.

Part number completion:
Version codes see page 98.
Tolerance: 20 % = M
10 % = K
5 % = J
Packing: bulk = S
Pin length: 6-2 = SD
none = 00 (for plate versions)

Rights reserved to amend design data without prior notification.

Continuation page 89

Continuation

General Data

Capacitance	2500 VDC/700 VAC*				3000 VDC/700 VAC*				
	W	H	L	Part number	W	H	L	Part number	
0.047 μ F	11	21	31.5	SNMPV024706B	11	21	31.5	SNMPW024706B	
	11	22	41.5	SNMPV024707B	11	22	41.5	SNMPW024707B	
	0.068 "	13	24	31.5	SNMPV026806D	13	24	31.5	SNMPW026806D
		11	22	41.5	SNMPV026807B	11	22	41.5	SNMPW026807B
0.1 μ F	15	26	31.5	SNMPV031006F	15	26	31.5	SNMPW031006F	
	13	24	41.5	SNMPV031007C	13	24	41.5	SNMPW031007C	
0.15 "	15	26	41.5	SNMPV031507D	15	26	41.5	SNMPW031507D	
0.22 "	19	32	41.5	SNMPV032207F	19	32	41.5	SNMPW032207F	
0.33 "	24	45.5	41.5	SNMPV033307H	24	45.5	41.5	SNMPW033307H	
0.47 "	31	46	41.5	SNMPV034707I	31	46	41.5	SNMPW034707I	
	27	37.5	56	SNMPV034708H	27	37.5	56	SNMPW034708H	
0.68 "	35	50	41.5	SNMPV036807J	35	50	41.5	SNMPW036807J	
	33	48	56	SNMPV036808J	33	48	56	SNMPW036808J	
1.0 μ F	40	55	41.5	SNMPV041007K	40	55	41.5	SNMPW041007K	
	33	48	56	SNMPV041008J	33	48	56	SNMPW041008J	
1.5 "	37	54	56	SNMPV041508L	37	54	56	SNMPW041508L	

* AC voltages: $f \leq 1000$ Hz; $1.4 \times U_{rms} + U_{DC} \leq U_r$

Dims. in mm.

Ionisation inception level in isolated cases may be lower than admissible rated AC voltage.

Versions and dimensional drawings see page 96.

Part number completion:

Version codes see page 98.

Tolerance: 20 % = M

10 % = K

5 % = J

Packing: bulk = S

Pin length: 6-2 = SD

none = 00 (for plate versions)

Rights reserved to amend design data without prior notification.

Impedance change with frequency (general guide) (examples).

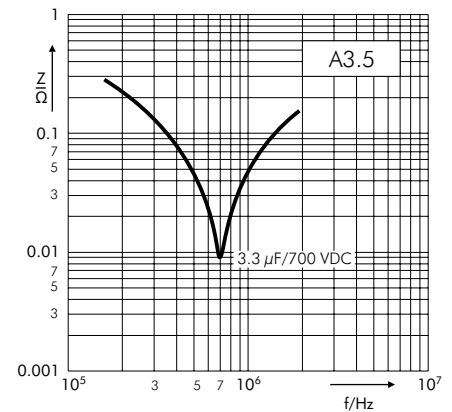
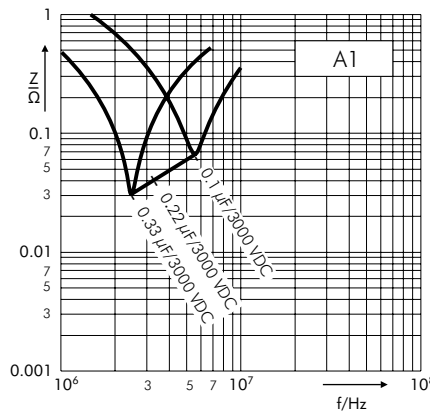

Continuation

Permissible AC voltage in relation to frequency till 15° C internal temperature rise (general guide).

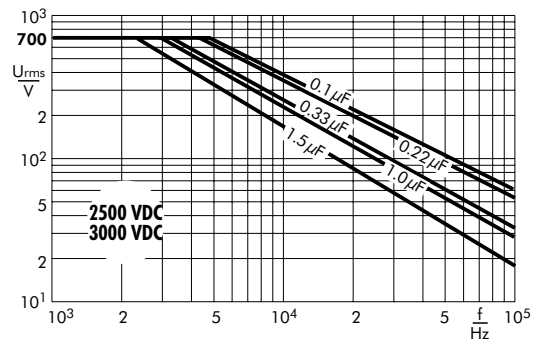
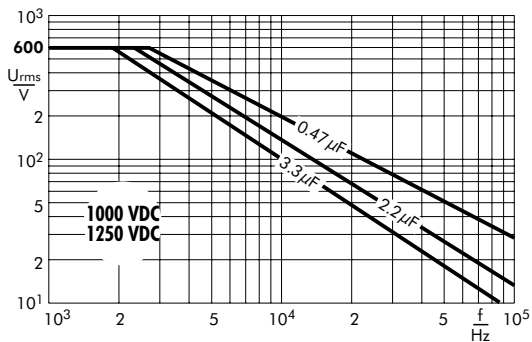
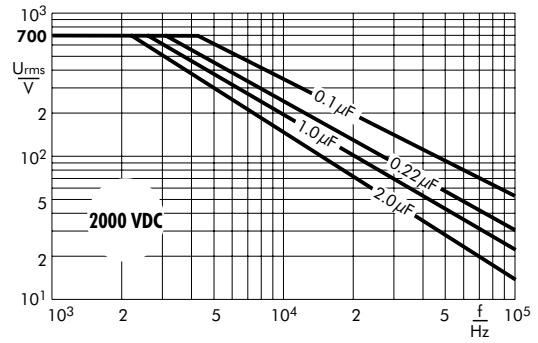
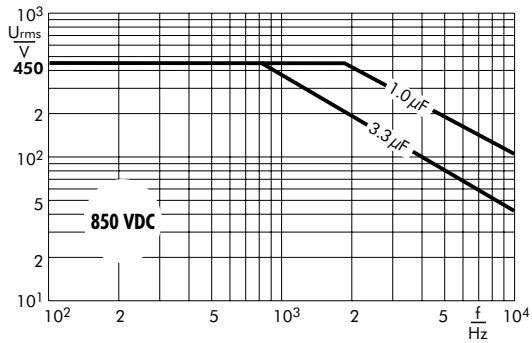
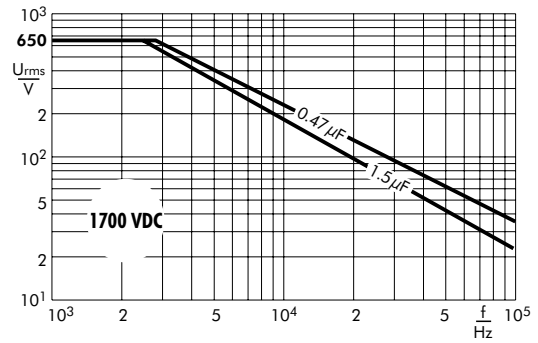
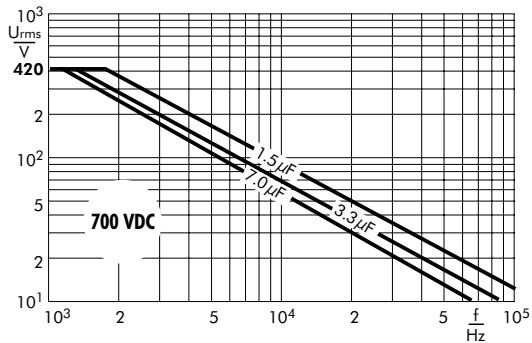

Continuation

Permissible AC current in relation to frequency till 15° C internal temperature rise (general guide).

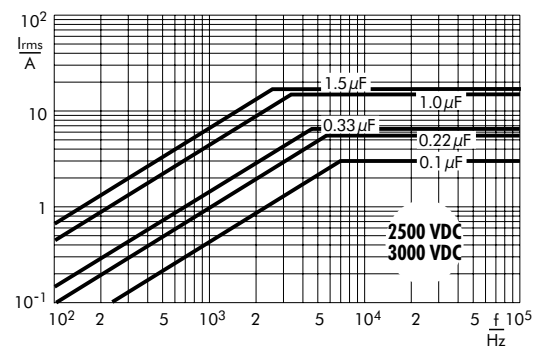
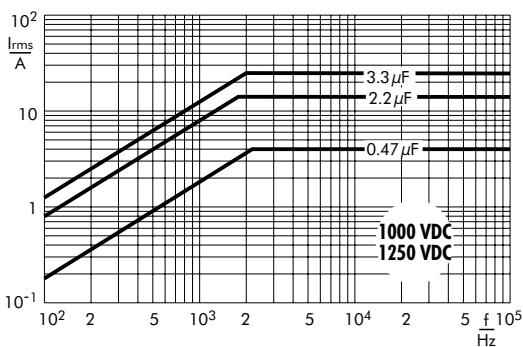
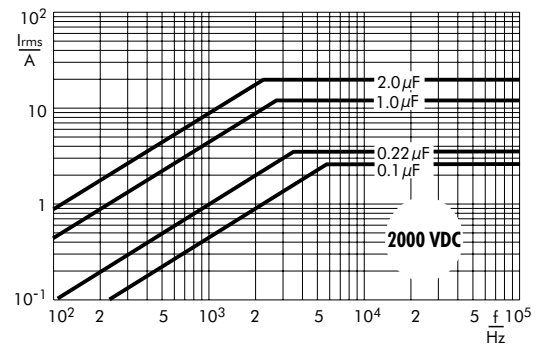
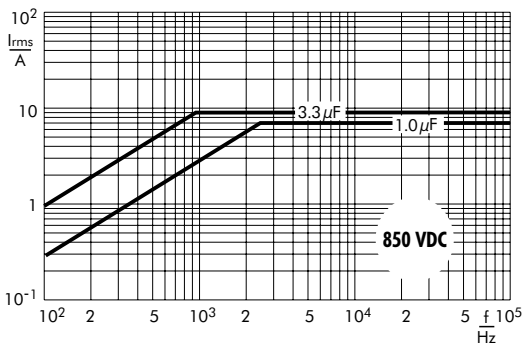
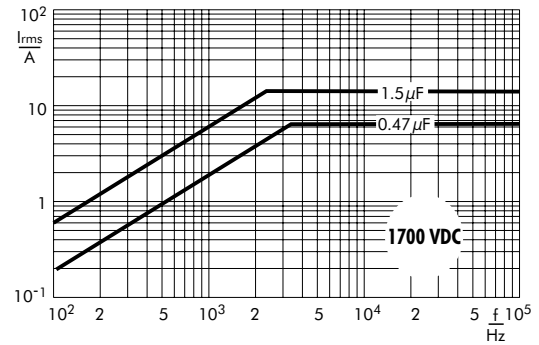
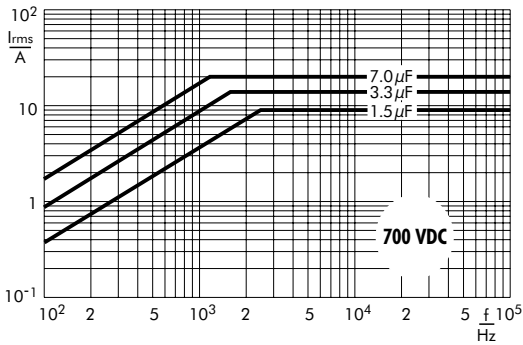

Versions of WIMA Snubber-Capacitors

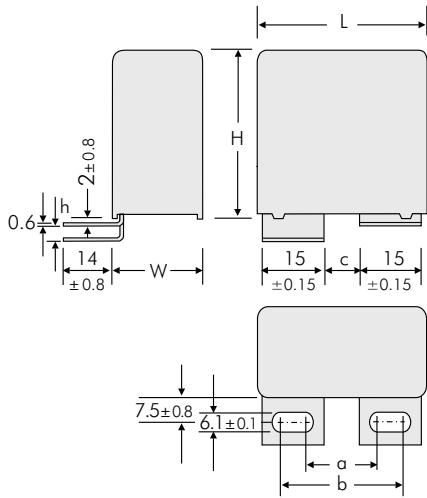

Version	L	a ±0.5	b ±0.5	c ±0.5	h ±0.8
A1	41.5	17.5	28	7.5	0
A1.5	41.5	17.5	28	7.5	3.5
A1	56	20	30	10	0
A1.1.1	56	28	38	18	0
A1.4.1	56	28	38	18	3.5

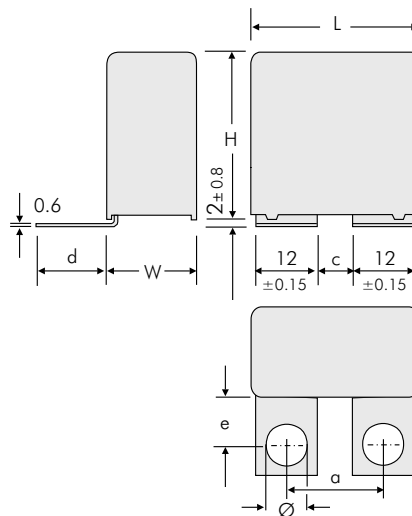

Version	L	a ±0.5	c ±0.5	d ±0.8	e ±0.8	Ø ±0.1
A1.6	41.5	18	6	21.5	16	7
A1.6.1	41.5	22	10	18.5	13	7
A1.6.2	41.5	23	10	18.5	13	8
A1.6	56	29	17	21.5	16	7

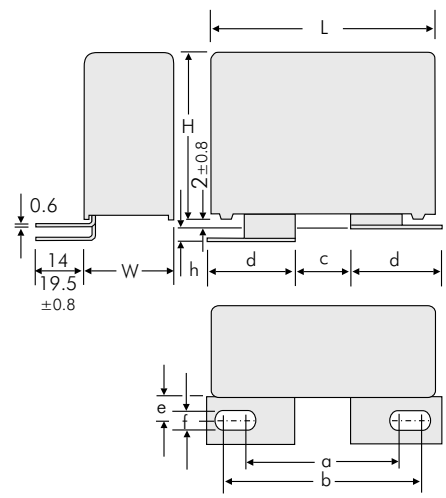

Version	L	a ±0.5	b ±0.5	c ±0.5	d ±0.15	e ±0.8	f ±0.1	h ±0.8
A2	41.5	36	46.5	14.5	22	7.5	8.4	0
A2.4.1	41.5	33.5	39.5	7.5	22	13	8.4	0
A2.6.1	41.5	31.5	41.5	14	22	13	6.1	3.5
A2.6.2	41.5	31.5	41.5	14	22	13	6.1	0
A2.8	41.5	36	46.5	14.5	22	7.5	8.4	3.5
A2.1	56	39.5	45.5	13.5	22	7.5	8.4	0
A2.1.2	56	36	45.5	14.5	21.5	7.5	8.4	0

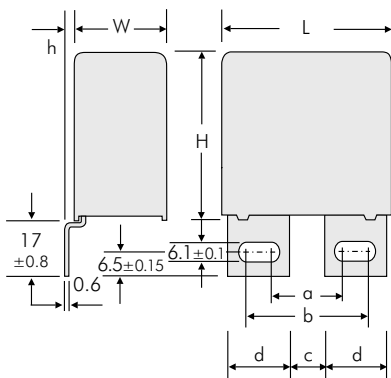

Version	L	a ±0.5	b ±0.5	c ±0.5	d ±0.15	h ±0.8
A3	41.5	17.5	27.5	7.5	15	0
A3.5	41.5	17.5	27.5	7.5	15	3
A3.12	41.5	17.5	30	7.5	16.5	0
A3	56	20	30	10	15	0
A3.1	56	28	38	18	15	0
A3.5	56	20	30	10	15	3
A3.10	56	28	38	18	15	3

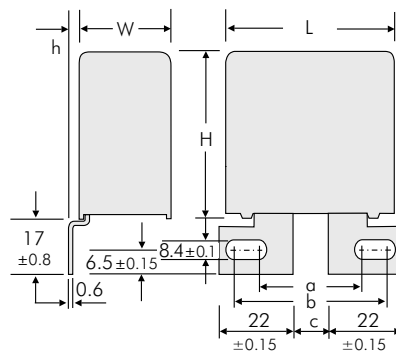

Version	L	a ±0.5	b ±0.5	c ±0.5	h ±0.8
A3.9	41.5	36	46.5	14.5	0
A3.11	41.5	36	46.5	14.5	3
A3.2	56	36	46.5	14.5	0
A3.3	56	36	46.5	14.5	3

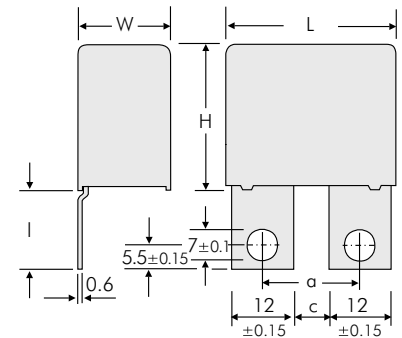

Version	L	a ±0.5	c ±0.5	l ±0.8
A3.8	41.5	18	6	23
A3.8.1	41.5	22	10	17.5
A3.8.2	41.5	22	10	23

Versions of WIMA Snubber-Capacitors

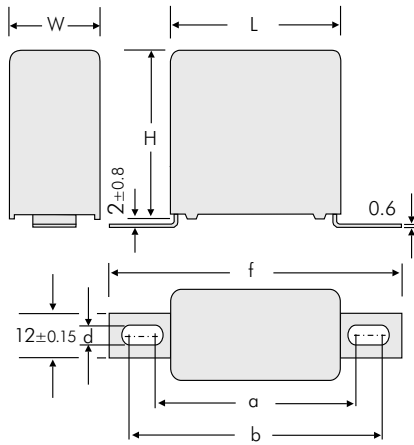

Version	L	a ±0.8	b ±0.8	f ±0.8	d ±0.1
A4.9	31.5 W ≥ 15	44	47	57	4.5
A4.10	31.5 W ≥ 15	43	59	69	6.1
A4.2	41.5 W ≥ 15	54	57	67	4.5
A4	41.5 W ≥ 15	53	69	79	6.1
A4.7	56	65	68	78	4.5
A4	56	64	80	90	6.1

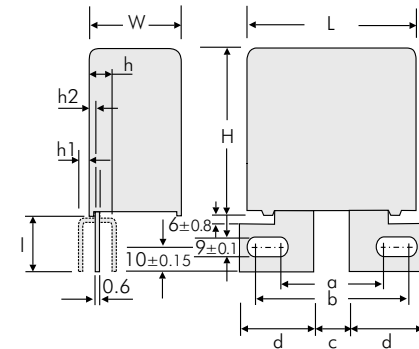

Version	W	a ±0.5	b ±0.5	c ±0.5	d ±0.15	h ±0.8	h1 ±0.8	h2 ±0.8	l ±0.8
A6	≥ 23	41.5	45.5	15.5	24.15	7	-	-	26
A6.3	≥ 19	35	39	18	19	-	5	3	25
A6.4	≥ 23	42.8	44.8	21	21.5	-	-	6.4	26

2-pin version

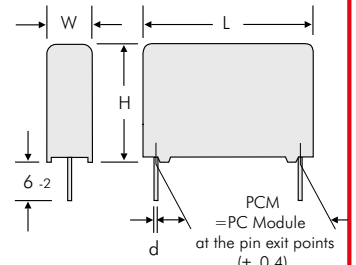

PCM	d
27.5	0.8
38.5	1.2
49.5	1.2

Dims. in mm

4-pin version

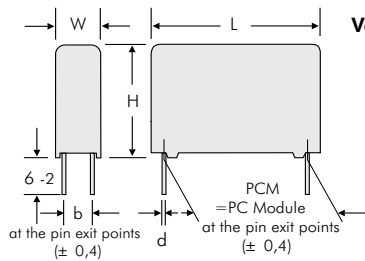

Version B

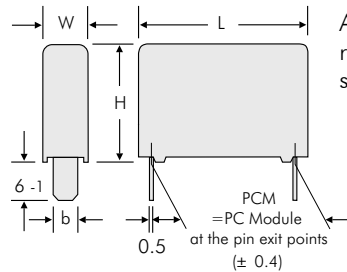

Additional special versions can be realized. Please contact us with your specific needs.

W	H	L	PCM	b	d
11	21	31.5	27.5	5	0.8
13	24	31.5	27.5	7.5	0.8
15	26	31.5	27.5	7.5	0.8
17	29	31.5	27.5	10	0.8
19	30	31.5	27.5	10	0.8
17	34.5	31.5	27.5	10	0.8
20	39.5	31.5	27.5	12.5	0.8
22	43.5	31.5	27.5	12.5	0.8
11	22	41.5	37.5	5	1
13	24	41.5	37.5	7.5	1
15	26	41.5	37.5	7.5	1
17	29	41.5	37.5	10	1
19	32	41.5	37.5	10	1
20	39.5	41.5	37.5	12.5	1
24	45.5	41.5	37.5	12.5	1
31	46	41.5	37.5	20	1
35	50	41.5	37.5	20	1
40	55	41.5	37.5	20	1
19	31	56	48.5	12.5	1
23	34	56	48.5	15	1
27	37.5	56	48.5	15	1
33	48	56	48.5	20	1
37	54	56	48.5	20	1

L	PCM	b ±0.15
31.5	28.5	8
41.5	38.5	8
56	49.5	8

Versions of WIMA Snubber-Capacitors



Version code		D2	D4	B8	1A	1B	1G	1H	1I	1J	1S	2A	2B	2Q	2F	2J	2K	2M	3A	3C	3D	3E	3G	3K	3L	3M	3N	3O	3P	3Q	4A	4C	4J	4L	4M	6A	6B	6C							
W x H x L	Size code	2-pin	4-pin	B8	A1	A1.1.1	A1.4.1	A1.5	A1.6	A1.6.1	A1.6.2	A2	A2.1	A2.1.2	A2.4.1	A2.6.1	A2.6.2	A2.8	A3	A3.1	A3.2	A3.3	A3.5	A3.8	A3.8.1	A3.8.2	A3.9	A3.10	A3.11	A3.12	A4	A4.2	A4.7	A4.9	A4.10	A6	A6.3	A6.4							
		11 x 21 x 31.5	6B																																										
13 x 24 x 31.5	6D																																												
15 x 26 x 31.5	6F																																												
17 x 29 x 31.5	6G																																												
17 x 34.5 x 31.5	6I																																												
11 x 22 x 41.5	7B																																												
13 x 24 x 41.5	7C																																												
15 x 26 x 41.5	7D																																												
17 x 29 x 41.5	7E																																												
19 x 32 x 41.5	7F																																												
20 x 39.5 x 41.5	7G																																												
24 x 45.5 x 41.5	7H																																												
31 x 46 x 41.5	7I																																												
35 x 50 x 41.5	7J																																												
40 x 55 x 41.5	7K																																												
19 x 31 x 56	8D																																												
23 x 34 x 56	8E																																												
27 x 37.5 x 56	8H																																												
33 x 48 x 56	8J																																												
37 x 54 x 56	8L																																												

Possible connecting respective plate versions - depending on box size.

■ 4-pin versions on request.

Recommendation for Processing and Application of Through-Hole Capacitors

Soldering Process

Internal temperature of the capacitor must be kept as follows:

Polyester: preheating: $T_{max.} \leq 125^{\circ}C$
soldering: $T_{max.} \leq 135^{\circ}C$

Polypropylene: preheating: $T_{max.} \leq 100^{\circ}C$
soldering: $T_{max.} \leq 110^{\circ}C$

Single wave soldering

Soldering bath temperature: $T < 260^{\circ}C$

Dwell time: $t < 5 \text{ sec}$

Double wave soldering

Soldering bath temperature: $T < 260^{\circ}C$

Dwell time: $\sum t < 5 \text{ sec}$

Due to different soldering processes and heat requirements the graphs are to be regarded as a recommendation only.

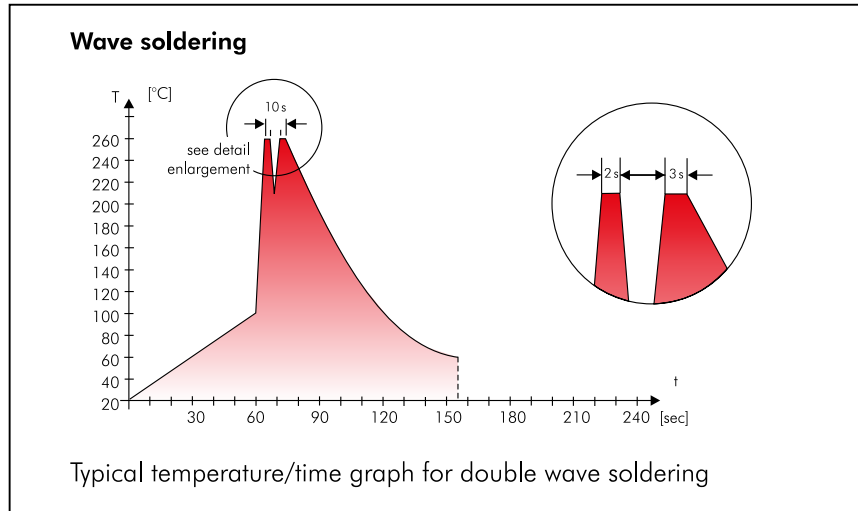

WIMA Quality and Environmental Philosophy

ISO 9001:2015 Certification

ISO 9001:2015 is an international basic standard of quality assurance systems for all branches of industry. The approval according to ISO 9001:2015 of our factories certifies that organisation, equipment and monitoring of quality assurance in our factories correspond to internationally recognized standards.

WIMA WPCS

The WIMA Process Control System (WPCS) is a quality surveillance and optimization system developed by WIMA. WPCS is a major part of the quality-oriented WIMA production. Points of application during production process:

- incoming material inspection
- metallization
- film inspection
- schoopage
- pre-healing
- pin attachment
- cast resin preparation/encapsulation
- 100% final inspection
- Testing as per customer requirements

WIMA Environmental Policy

All WIMA capacitors, irrespective of whether through-hole devices or SMD, are made of environmentally friendly materials. Neither during manufacture nor in the product itself any toxic substances are used, e.g.

- Lead
- PCB
- CFC
- Hydrocarbon chloride
- Chromium 6+
- PBB/PBDE
- Arsenic
- Cadmium
- Mercury
- etc.

We merely use pure, recyclable materials for packing our components, such as:

- carton
- cardboard
- adhesive tape made of paper
- polystyrene

We almost completely refrain from using packing materials such as:

- adhesive tapes made of plastic
- metal clips

RoHS Compliance

According to the RoHS Directive 2015/863/EU as amended from time to time certain hazardous substances like e.g. lead, cadmium, mercury must not be used any longer in electronic equipment as of July 1st, 2006. For the sake of the environment WIMA has re-frained from using such substances since years already.



WIMA Kondensatoren sind bleifrei konform RoHS 2015/863/EU
WIMA capacitors are lead free in accordance with RoHS 2015/863/EU

Tape for lead-free WIMA capacitors

DIN EN ISO 14001:2004

WIMA's environmental management has been established in accordance with the guidelines of DIN EN ISO 14001:2004 to optimize the production processes with regard to energy and resources.

Typical Dimensions for Taping Configuration

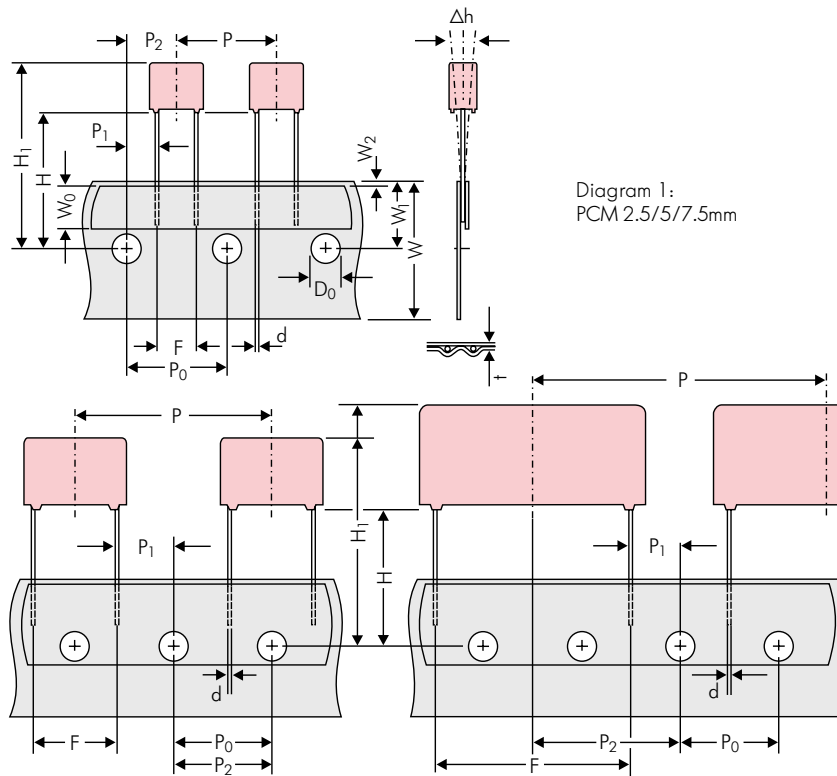

Diagram 1:
PCM 2.5/5/7.5mm

Diagram 2: PCM 10/15 mm

Diagram 3: PCM 22.5 and 27.5*mm

*PCM 27.5 tapping possible with two feed holes between components

Designation	Symbol	Dimensions for Radial Taping						
		PCM 2.5 tapping	PCM 5 tapping	PCM 7.5 tapping	PCM 10 tapping*	PCM 15 tapping*	PCM 22.5 tapping	PCM 27.5 tapping
Carrier tape width	W	18.0 ±0.5	18.0 ±0.5	18.0 ±0.5	18.0 ±0.5	18.0 ±0.5	18.0 ±0.5	18.0 ±0.5
Hold-down tape width	W ₀	6.0 for hot-sealing adhesive tape	6.0 for hot-sealing adhesive tape	12.0 for hot-sealing adhesive tape	12.0 for hot-sealing adhesive tape	12.0 for hot-sealing adhesive tape	12.0 for hot-sealing adhesive tape	12.0 for hot-sealing adhesive tape
Hole position	W ₁	9.0 ±0.5	9.0 ±0.5	9.0 ±0.5	9.0 ±0.5	9.0 ±0.5	9.0 ±0.5	9.0 ±0.5
Hold-down tape position	W ₂	0.5 to 3.0 max.	0.5 to 3.0 max.	0.5 to 3.0 max.	0.5 to 3.0 max.	0.5 to 3.0 max.	0.5 to 3.0 max.	0.5 to 3.0 max.
Feed hole diameter	D ₀	4.0 ±0.2	4.0 ±0.2	4.0 ±0.2	4.0 ±0.2	4.0 ±0.2	4.0 ±0.2	4.0 ±0.2
Pitch of component	P	12.7 ±1.0	12.7 ±1.0	12.7 ±1.0	25.4 ±1.0	25.4 ±1.0	38.1 ±1.5	*38.1 ±1.5 or 50.8 ±1.5
Feed hole pitch	P ₀	12.7 ±0.3 error max. 1.0 mm/20 pitch	12.7 ±0.3 error max. 1.0 mm/20 pitch	12.7 ±0.3 error max. 1.0 mm/20 pitch	12.7 ±0.3 error max. 1.0 mm/20 pitch	12.7 ±0.3 error max. 1.0 mm/20 pitch	12.7 ±0.3 error max. 1.0 mm/20 pitch	12.7 ±0.3 error max. 1.0 mm/20 pitch
Feed hole centre to pin	P ₁	5.1 ±0.5	3.85 ±0.7	2.6 ±0.7	7.7 ±0.7	5.2 ±0.7	7.8 ±0.7	5.3 ±0.7
Hole centre to component centre	P ₂	6.35 ±1.3	6.35 ±1.3	6.35 ±1.3	12.7 ±1.3	12.7 ±1.3	19.05 ±1.3	19.05 ±1.3
Feed hole centre to bottom edge of the component	H _▲	16.5 ±0.3 18.5 ±0.5	16.5 ±0.3 18.5 ±0.5	16.5 ±0.5 18.5 ±0.5	16.5 ±0.5 18.5 ±0.5	16.5 ±0.5 18.5 ±0.5	16.5 ±0.5 18.5 ±0.5	16.5 ±0.5 18.5 ±0.5
Feed hole centre to top edge of the component	H ₁	H+H _{component} < H ₁ 32.25 max.	H+H _{component} < H ₁ 32.25 max.	H+H _{component} < H ₁ 24.5 to 31.5	H+H _{component} < H ₁ 25.0 to 31.5	H+H _{component} < H ₁ 26.0 to 37.0	H+H _{component} < H ₁ 30.0 to 43.0	H+H _{component} < H ₁ 35.0 to 45.0
Pin spacing at upper edge of carrier tape	F	2.5 ±0.5	5.0 ^{+0.8} _{-0.2}	7.5 ±0.8	10.0 ±0.8	15 ±0.8	22.5 ±0.8	27.5 ±0.8
Pin diameter	d	0.4 ±0.05	0.5 ±0.05	*0.5 ±0.05 or 0.6 ^{+0.06} _{-0.05}	*0.5 ±0.05 or 0.6 ^{+0.06} _{-0.05}	0.8 ^{+0.08} _{-0.05}	0.8 ^{+0.08} _{-0.05}	0.8 ^{+0.08} _{-0.05}
Component alignment	Δh	± 2.0 max.	± 2.0 max.	± 3.0 max.	± 3.0 max.	± 3.0 max.	± 3.0 max.	± 3.0 max.
Total tape thickness	t	0.6 ±0.2	0.6 ±0.2	0.6 ±0.2	0.6 ±0.2	0.6 ±0.2	0.6 ±0.2	0.6 ±0.2
Package (see also page 134)	▲	ROLL/AMMO			AMMO			
		REEL Ø 360 max. Ø 30 ±1	B 52 ±2 58 ±2	depending on comp. dimensions	REEL Ø 360 max. Ø 30 ±1	B 52 ±2 58 ±2 66 ±2	or REEL Ø 500 max. Ø 25 ±1	B 54 ±2 60 ±2 68 ±2
Unit		see details page 135.						

▲ When ordering please specify dimension H and required packaging type.

Dims in mm.

• Diameter of pins see General Data.

Please clarify customer-specific deviations with the manufacturer.

* PCM 10 and PCM 15 can be crimped to PCM 7.5.

Position of components according to PCM 7.5 (sketch 1). P₀ = 12.7 or 15.0 is possible

Types of Tape Packaging of Capacitors for Automatic Radial Insertion

■ ROLL Packaging

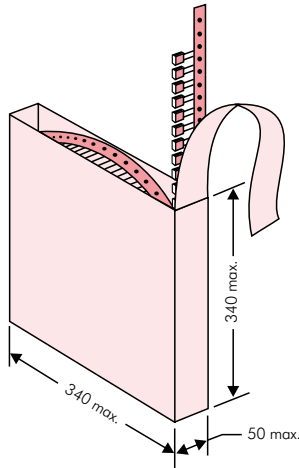

■ AMMO Packaging

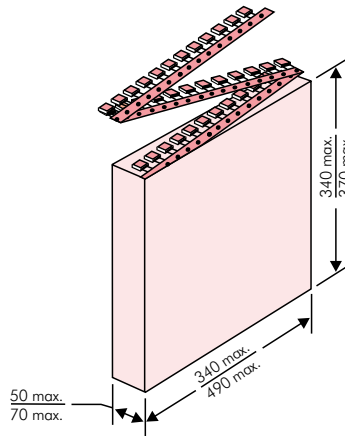

■ REEL Packaging

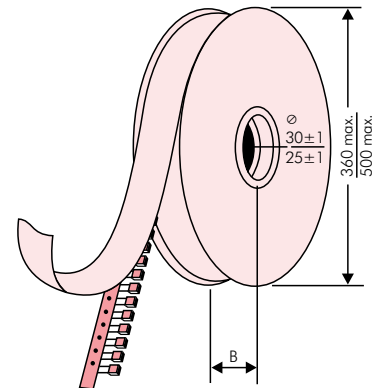

BAR CODE (Labelling)

Labelling of package units in plain text and with alphanumeric Bar Code

- WIMA supplier number
- Date code
- Customer's P/O number
- P/O line
- Customer's part number
- WIMA part number
- Quantity
- WIMA confirmation number
- Country of origin
- Customer name
- Handling unit number
- Week of delivery.

In addition part description of

- article
- capacitance value
- rated voltage
- dimensions
- technical note
- capacitance tolerance
- packing
- connecting information

BARCODE PDF417
BARCODE 2D Datamatrix

WIMA Best Capacitors Made in Germany
Werk Aurich

Supplier-ID: LIEF.NR.	Date Code: 20210419
Purchase Order No. (P/O): Bestellung xyz	P/O line: 100
Customer Part No.: KUNDENTEILENUMMER	
WIMA Part No.: MKP1F041006B00KSSD	Quantity: 459
WIMA Confirmation No.: 0001105072000100	RoHS 2011/65/EU
	COO: DE
Customer No.: 0000100002	
Gross Weight [g]: 4557	
WIMA – MKP 10	WIMA Part No.: MKP1F041006B00KSSD
MKP 10 1.0 µF 250 VDC 11x21x31.5 RM27.5	
Standard 10% Lose – Standard Drähte 6–2	
Vorlage Debitor Inland	
	0001105072000100
1002021443	QTY: 459 Week 19/2021

Packing Quantities for Capacitors with Radial Pins in PCM 2.5 mm to 22.5 mm



PCM	Size				bulk	pcs. per packing unit									
						ROLL		REEL				AMMO			
	W	H	L	Codes		S	N	O	Ø 360		Ø 500		340 x 340		490 x 370
								F	I	H	J	A	C	B	D
2.5 mm	2.5	7	4.6	0B	5000	2200		2500				2800			
	3	7.5	4.6	0C	5000	2000		2300				2300			
	3.8	8.5	4.6	0D	5000	1500		1800				1800			
	4.6	9	4.6	0E	5000	1200		1500				1500			
	5.5	10	4.6	0F	5000	900		1200				1200			
5 mm	2.5	6.5	7.2	1A	5000	2200		2500				2800			
	3	7.5	7.2	1B	5000	2000		2300				2300			
	3.5	8.5	7.2	1C	5000	1600		2000				2000			
	4.5	6	7.2	1D	6000	1300		1500				1500			
	4.5	9.5	7.2	1E	4000	1300		1500				1500			
	5	10	7.2	1F	3500	1100		1400				1400			
	5.5	7	7.2	1G	4000	1000		1200				1200			
	5.5	11.5	7.2	1H	2500	1000		1200				1200			
	6.5	8	7.2	1I	2500	800		1000				1000			
	7.2	8.5	7.2	1J	2500	700		1000				1000			
	7.2	13	7.2	1K	2000	700		950				1000			
	8.5	10	7.2	1L	2000	600		800				800			
	8.5	14	7.2	1M	1500	600		800				800			
11	16	7.2	1N	1000	500		600				640				
11	18	7.2	1O	1000	500		600				640				
7.5 mm	2.5	7	10	2A	5000	–		2500		4400		2500		–	
	3	8.5	10	2B	5000	–		2200		4300		2300		4150	
	4	9	10	2C	4000	–		1700		3200		1700		3000	
	4.5	9.5	10.3	2D	3500	–		1500		2900		1400		2700	
	5	10.5	10.3	2E	3000	–		1300		2500		1300		–	
	5.7	12.5	10.3	2F	2000	–		1000		2200		1100		–	
	7.2	12.5	10.3	2G	1500	–		900		1800		1000		–	
10 mm	4	9	13	3C	3000	–		900		1600		–		1450	
	4	9.5	13	3D	3000	–		900		1600		–		1400	
	5	11	13	3F	3000	–		700		1300		–		1100	
	6	12	13	3G	2400	–		550		1100		–		1000	
	6	12.5	13	3H	2400	–		550		1100		–		1000	
	8	12	13	3I	2000	–		400		800		–		740	
15 mm	5	11	18	4B	2400	–		600		1200		–		1150	
	6	12.5	18	4C	2000	–		500		1000		–		1000	
	7	14	18	4D	1600	–		450		900		–		850	
	8	15	18	4F	1200	–		400		800		–		740	
	9	14	18	4H	1200	–		350		700		–		650	
	9	16	18	4J	900	–		350		700		–		650	
	11	14	18	4M	1000	–		300		600		–		540	
22.5 mm	5	14	26.5	5A	1200	–		–		800		–		770	
	6	15	26.5	5B	1000	–		–		700		–		640	
	7	16.5	26.5	5D	760	–		–		600		–		550	
	8.5	18.5	26.5	5F	500	–		–		480		–		450	
	10.5	19	26.5	5G	594*	–		–		400		–		360	
	10.5	20.5	26.5	5H	594*	–		–		400		–		360	
	11	21	26.5	5I	561*	–		–		380		–		350	

* for 2-inch transport pitches.

* TPS (Tray-Packing-System). Plate versions may have different packing units. Samples and pre-production needs on request.

Rights reserved to amend design data without prior notification.



Packing Quantities for Capacitors with Radial Pins in PCM 27.5 mm to 52.5 mm

PCM	Size				bulk	pcs. per packing unit									
						ROLL		REEL				AMMO			
	W	H	L	Codes		S	N	O	Ø 360		Ø 500		340 x 340		490 x 370
								F	I	H	J	A	C	B	D
27.5 mm	9	19	31.5	6A	567*	-	-	-	-	-	460/340*	-	-	-	-
	11	21	31.5	6B	459*	-	-	-	-	-	380/280*	-	-	-	-
	13	24	31.5	6D	378*	-	-	-	-	-	300	-	-	-	-
	15	26	31.5	6F	324*	-	-	-	-	-	270	-	-	-	-
	17	29	31.5	6G	198*	-	-	-	-	-	-	-	-	-	-
	17	34.5	31.5	6I	198*	-	-	-	-	-	-	-	-	-	-
	20	39.5	31.5	6J	162*	-	-	-	-	-	-	-	-	-	-
37.5 mm**	9	19	41.5	7A	441*	-	-	-	-	-	-	-	-	-	
	11	22	41.5	7B	357*	-	-	-	-	-	-	-	-	-	
	13	24	41.5	7C	294*	-	-	-	-	-	-	-	-	-	
	15	26	41.5	7D	252*	-	-	-	-	-	-	-	-	-	
	17	29	41.5	7E	154*	-	-	-	-	-	-	-	-	-	
	19	32	41.5	7F	140*	-	-	-	-	-	-	-	-	-	
	20	39.5	41.5	7G	126*	-	-	-	-	-	-	-	-	-	
	24	45.5	41.5	7H	112*	-	-	-	-	-	-	-	-	-	
	28	38	41.5	7L	84*	-	-	-	-	-	-	-	-	-	
	31	46	41.5	7I	84*	-	-	-	-	-	-	-	-	-	
	35	50	41.5	7J	35*	-	-	-	-	-	-	-	-	-	
40	55	41.5	7K	28*	-	-	-	-	-	-	-	-	-		
48.5 mm**	19	31	56	8D	120*	-	-	-	-	-	-	-	-		
	23	34	56	8E	80*	-	-	-	-	-	-	-	-		
	27	37.5	56	8H	84*	-	-	-	-	-	-	-	-		
	33	48	56	8J	25*	-	-	-	-	-	-	-	-		
	37	54	56	8L	25*	-	-	-	-	-	-	-	-		
52.5 mm	25	45	57	9D	70*	-	-	-	-	-	-	-	-		
	30	45	57	9E	60*	-	-	-	-	-	-	-	-		
	35	50	57	9F	25*	-	-	-	-	-	-	-	-		
	45	55	57	9H	20*	-	-	-	-	-	-	-	-		
	45	65	57	9J	20*	-	-	-	-	-	-	-	-		

* TPS (Tray-Packing-System). Plate versions may have different packing units.

Rights reserved to amend design data without prior notification.

**For Snubber capacitors in 2-pin version the PCM is changing to 38.5 respective 49.5 mm. Samples and pre-production needs on request.

Updated data on www.wima.com



A WIMA part number consists of 18 digits and is composed as follows:

- Field 1 - 4: Type description
- Field 5 - 6: Rated voltage
- Field 7 -10: Capacitance
- Field 11 -12: Size and PCM
- Field 13 -14: Version code (e.g. Snubber versions)
- Field 15: Capacitance tolerance
- Field 16: Packing
- Field 17 -18: Pin length (untaped)

1	2	3	4	5	6	7	8	9	10	11	12	13	14	15	16	17	18
M	K	S	2	C	0	2	1	0	0	1	A	0	0	M	S	S	D
MKS 2				63 VDC		0.01 µF			2.5x6.5x7.2			-		20%	bulk	6 -2	

<p>Type description:</p> <p>SMD-PET = SMDT SMD-PPS = SMDI MKS 02 = MKS0 FKS 2 = FKS2 FKP 2 = FKP2 MKS 2 = MKS2 MKP 2 = MKP2 MKS 4 = MKS4 MKP 4 = MKP4 MKP 10 = MKP1 FKP 1 = FKP1 MKP-X2 = MKX2 MKP-X1 R = MKX1 MKP-Y2 = MKY2 Snubber MKP = SNMP Snubber FKP = SNFP GTO MKP = GTOM DC-LINK MKP 4 = DCP4 DC-LINK MKP 6 = DCP6 DC-LINK HC = DCHC</p>	<p>Rated voltage:</p> <p>63 VDC = C0 100 VDC = D0 250 VDC = F0 400 VDC = G0 450 VDC = H0 520 VDC = H2 600 VDC = I0 630 VDC = J0 700 VDC = K0 800 VDC = L0 850 VDC = M0 900 VDC = N0 1000 VDC = O1 1100 VDC = P0 1200 VDC = Q0 1250 VDC = R0 1500 VDC = S0 1600 VDC = T0 1700 VDC = TA 2000 VDC = U0 2500 VDC = V0 3000 VDC = W0 4000 VDC = X0 6000 VDC = Y0 230 VAC = 3Y 275 VAC = 1W 300 VAC = 2W 305 VAC = AW 350 VAC = BW 440 VAC = 4W ...</p>	<p>Capacitance:</p> <p>22 pF = 0022 47 pF = 0047 100 pF = 0100 150 pF = 0150 220 pF = 0220 330 pF = 0330 470 pF = 0470 680 pF = 0680 1000 pF = 1100 1500 pF = 1150 2200 pF = 1220 3300 pF = 1330 4700 pF = 1470 6800 pF = 1680 0.01 µF = 2100 0.022 µF = 2220 0.047 µF = 2470 0.1 µF = 3100 0.22 µF = 3220 0.47 µF = 3470 1 µF = 4100 2.2 µF = 4220 4.7 µF = 4470 10 µF = 5100 22 µF = 5220 47 µF = 5470 100 µF = 6100 220 µF = 6220 1000 µF = 7100 1500 µF = 7150 ...</p>	<p>Size:</p> <p>4.8x3.3x3 Size 1812 = KA 4.8x3.3x4 Size 1812 = KB 5.7x5.1x3.5 Size 2220 = QA 5.7x5.1x4.5 Size 2220 = QB 7.2x6.1x3 Size 2824 = TA 7.2x6.1x5 Size 2824 = TB 10.2x7.6x5 Size 4030 = VA 12.7x10.2x6 Size 5040 = XA 15.3x13.7x7 Size 6054 = YA 2.5x7x4.6 PCM2.5 = 0B 3x7.5x4.6 PCM2.5 = 0C 2.5x6.5x7.2 PCM5 = 1A 3x7.5x7.2 PCM5 = 1B 2.5x7x10 PCM7.5 = 2A 3x8.5x10 PCM7.5 = 2B 3x9x13 PCM10 = 3A 4x9x13 PCM10 = 3C 5x11x18 PCM15 = 4B 6x12.5x18 PCM15 = 4C 5x14x26.5 PCM22.5 = 5A 6x15x26.5 PCM22.5 = 5B 9x19x31.5 PCM27.5 = 6A 11x21x31.5 PCM27.5 = 6B 9x19x41.5 PCM37.5 = 7A 11x22x41.5 PCM37.5 = 7B 19x31x56 PCM 48.5 = 8D 25x45x57 PCM 52.5 = 9D ...</p>	<p>Tolerance:</p> <p>±20% = M ±10% = K ±5% = J ±2.5% = H ±1% = E ...</p> <p>Packing:</p> <p>AMMO H16.5 340x340 = A AMMO H16.5 490x370 = B AMMO H18.5 340x340 = C AMMO H18.5 490x370 = D REEL H16.5 360 = F REEL H16.5 500 = H REEL H18.5 360 = I REEL H18.5 500 = J ROLL H16.5 = N ROLL H18.5 = O BLISTER W12 180 = P BLISTER W12 330 = Q BLISTER W16 330 = R BLISTER W24 330 = T Bulk/TPS Standard = S ...</p>	
				<p>Version code:</p> <p>Standard = 00 Version A1 = 1A Version A1.1.1 = 1B Version A2 = 2A ...</p>	<p>Pin length (untaped)</p> <p>3.5 ±0.5 = C9 6 -2 = SD 16 ±1 = P1 ...</p> <p>Pin length (taped)</p> <p>none = 00</p>

The data on this page is not complete and serves only to explain the part number system. Part number information is listed on the pages of the respective WIMA range.