

CA45 Chip Tantalum Capacitors (SMD Tantalum Capacitors)

◆ Brief Introduction

- General purpose SMT chip tantalum series
- General low power DC/DC and LDO
- Operating Standard: QJ/PWV109-2003
- Military Part Qualified Factory
- RoHS and REACH Compliance



Yellow and black color are available

◆ Specifications

- Operating Temperature Range: -55 °C ~ +125 °C; >85 °C(with rated voltage derating);
- DC Leakage at 25°C: $I_0 \leq 0.01C_R U_R$ or 0.5uA (Choose the greater one)
- Capacitance Range: 0.68uF~1000uF
- Voltage Range: 2.5V, 4V, 6.3V, 10V, 16V, 20V, 25V, 35V, 50V
- Capacitance Tolerance: K: +/-10%; M: +/-20% (+/-20% tolerance is standard)
- SPQ: A,B case: 2000pcs/reel; C,D case: 500pcs/reel; E case: 400pcs/reel
- How to order, please refer to Part Number System

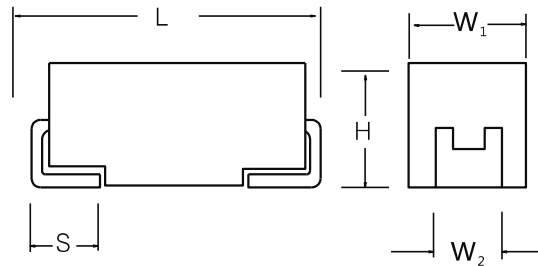

◆ Table 1 Dimensions (Unit: mm)

Case size	EIA Code	EIA Metric	L	W ₁	H	S	W ₂
A	1206	3216-16	3.20±0.20	1.60+0.20	1.60±0.20	0.80±0.20	1.20±0.20
B	1210	3528-19	3.50±0.20	2.80±0.20	1.90±0.20	0.80±0.20	2.20±0.20
C	2312	6032-25	6.00±0.20	3.20±0.20	2.50±0.20	1.30±0.20	2.20±0.20
D	2917	7343-28	7.30±0.20	4.30±0.20	2.80±0.20	1.30±0.20	2.40±0.20
E	2917	7343-43	7.30±0.40	4.30±0.40	4.10±0.40	1.30±0.20	2.40±0.20
V	2924	7361-36	7.30±0.40	6.10±0.40	3.60±0.40	1.35±0.20	3.00±0.20

◆ Markings on Chip Tantalum Capacitor Body (may other more markings)

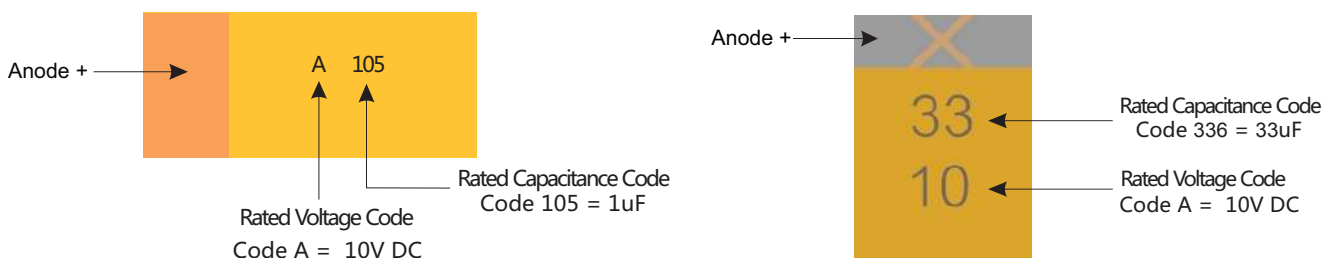

Voltage Code Table for Chip Tantalum Capacitors

Voltage Code	G	J	A	C	D	E	V	H	T
Rated Voltage	4V	6.3V	10V	16V	20V	25V	35V	40V	50V

CA45 Chip Tantalum Capacitors (SMD Tantalum Capacitors)

◆Table 2 Temperature Characteristics

Max					
tgδ(%)				DCL μA	
-55°C	25°C	85°C	125°C	85°C	125°C
6	4	6		8 I _o	10 I _o
8	6	8			
10	8	10			
12	10	12			
14	12	14			
18	16	18			

◆Table 3 Packaging information

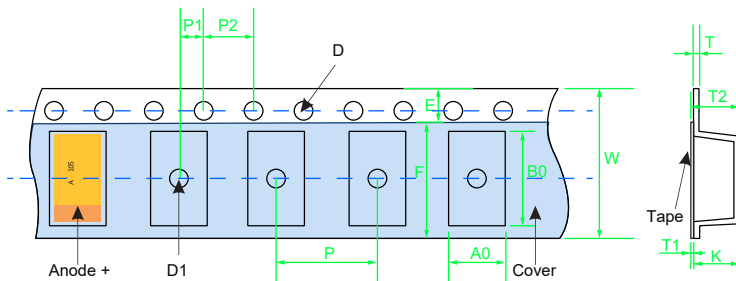

Picture 1

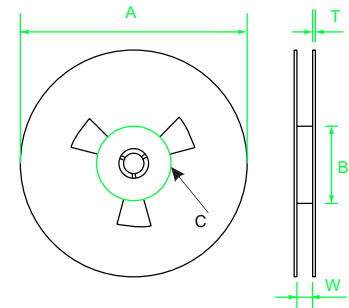

Picture 2

Dimensions of tape (picture 1)

CASE	A ₀ ±0.10	B ₀ ±0.10	K±0.10	W±0.30	E±0.10	F±0.05	P±0.10	P ₁ ±0.05	P ₂ ±0.10	D±0.20	D ₁ ±0.25
A	1.88	3.53	1.95	8.0±0.10	1.75	3.5	4	2	4	1.5±0.10	1.0±0.10
B	3.20	3.80	1.90	8	1.75	3.5	4	2	4	1.5	1
C	3.45	6.4	2.92	12	1.75	5.5	8	2	4	1.5	1.5
D	4.48	7.62	3.22	12	1.75	5.5	8	2	4	1.5	1.5
E	4.5	7.5	4.5	12	1.75	5.5	8	2	4	1.5	1.5
V	6.4	7.6	4.4	12	1.75	5.5	8	2	4	1.5	1.5

The tolerance is +/-0.2mm when the holes are more than 10PCS

Dimensions of reel (picture 2)

Size of reel	Width of tape	A	B	C	W	T
180mm (7")	8mm	178±2.00	50 min	13.0±0.50	8.4+1.5/-0	1.50±0.50
180mm (7")	12mm	178±2.00	50 min	13.0±0.50	12.4+1.5/-0	1.50±0.50
180mm (7")	16mm	178±2.00	50 min	13.0±0.50	16.4+1.5/-1	1.50±0.50

Packaging quantity

CASE	A	B	C	D	E	V
Quantity (PCS/reel)	2000	2000	500	500	400	400

◆ How to order

<u>CA45</u>	<u>B</u>	<u>227</u>	<u>M</u>	<u>010</u>	<u>R</u>	<u>-</u>
↓	↓	↓	↓	↓	↓	↓
<u>Type</u>	<u>Case Size</u>	<u>Capacitance code</u>	<u>Tolerance</u>	<u>Rated DC Voltage</u>	<u>Package</u>	<u>Additional characters may be added for special requirements</u>
CA45	See size table	pF Code: 1st two digits represent significant figures 3rd digit represents multiplier (number of zeros to follow) 106 = 10uF 107 = 100uF 227 = 220uF	K: +/-10% M: +/-20%	Code 035: 35VDC 006 = 6.3VDC 010 = 10VDC 025 = 25VDC 035 = 35VDC 050 = 50VDC	R: Tape & Reel	

CA45 Chip Tantalum Capacitors (SMD Tantalum Capacitors)

◆Table 4 Electrical Characteristics

Part Number	Case Code	Nominal Capacitance	Rated Voltage	Rated Temperature	Category Voltage	Category Temperature	Max DCL at +25°C	Max DF at +25°C 100Hz	Max ESR +25°C	Ripple Current (A) 100KHz Max		
										+25°C	+85°C	+125°C
		µF	V	°C	V	°C	µA	%	Ω			
CA45A336#002R	A	33	2.5	85	1.7	125	0.8	8	3.0	0.158	0.142	0.063
CA45A476#002R	A	47	2.5	85	1.7	125	1.2	6	3.0	0.158	0.142	0.063
CA45A686#002R	A	68	2.5	85	1.7	125	1.7	8	2.5	0.173	0.156	0.069
CA45A107#002R	A	100	2.5	85	1.7	125	2.5	20	3.0	0.158	0.142	0.063
CA45B107#002R	B	100	2.5	85	1.7	125	2.5	8	2.0	0.206	0.186	0.082
CA45B157#002R	B	150	2.5	85	1.7	125	3.8	10	1.8	0.217	0.196	0.087
CA45B227#002R	B	220	2.5	85	1.7	125	5.5	16	1.6	0.230	0.207	0.092
CA45D227#002R	D	220	2.5	85	1.7	125	5.5	8	0.8	0.433	0.390	0.173
CA45D337#002R	D	330	2.5	85	1.7	125	8.3	8	0.3	0.707	0.636	0.283
CA45C477#002R	C	470	2.5	85	1.7	125	12.0	12	0.5	0.469	0.422	0.188
CA45D477#002R	D	470	2.5	85	1.7	125	12.0	8	0.4	0.612	0.551	0.245
CA45C687#002R	C	680	2.5	85	1.7	125	17.0	18	0.6	0.428	0.385	0.171
CA45D687#002R	D	680	2.5	85	1.7	125	17.0	16	0.5	0.548	0.493	0.219
CA45E687#002R	E	680	2.5	85	1.7	125	17.0	10	0.5	0.574	0.517	0.230
CA45D108#002R	D	1000	2.5	85	1.7	125	25.0	18	0.5	0.548	0.493	0.219
CA45E108#002R	E	1000	2.5	85	1.7	125	25.0	14	0.4	0.642	0.578	0.257
CA45D158#002R	D	1500	2.5	85	1.7	125	38.0	20	0.4	0.612	0.551	0.245
CA45E158#002R	E	1500	2.5	85	1.7	125	38.0	14	0.3	0.742	0.667	0.297
CA45V158#002R	V	1500	2.5	85	1.7	125	38.0	14	0.2	1.118	1.006	0.447
CA45V228#002R	V	2200	2.5	85	1.7	125	55.0	20	0.4	0.791	0.712	0.316
CA45A225#004R	A	2.2	4	85	2.7	125	0.5	6	3.0	0.158	0.142	0.063
CA45A335#004R	A	3.3	4	85	2.7	125	0.5	6	3.0	0.158	0.142	0.063
CA45A475#004R	A	4.7	4	85	2.7	125	0.5	6	3.0	0.158	0.142	0.063
CA45B475#004R	B	4.7	4	85	2.7	125	0.5	6	2.0	0.206	0.186	0.082
CA45A685#004R	A	6.8	4	85	2.7	125	0.5	6	2.5	0.173	0.156	0.069
CA45B685#004R	B	6.8	4	85	2.7	125	0.5	6	2.0	0.206	0.186	0.082
CA45A106#004R	A	10	4	85	2.7	125	0.5	6	3.0	0.158	0.142	0.063
CA45B106#004R	B	10	4	85	2.7	125	0.5	6	2.5	0.184	0.166	0.074
CA45A156#004R	A	15	4	85	2.7	125	0.6	6	3.0	0.158	0.142	0.063
CA45B156#004R	B	15	4	85	2.7	125	0.6	6	2.5	0.184	0.166	0.074
CA45C156#004R	C	15	4	85	2.7	125	0.6	6	1.5	0.271	0.244	0.108
CA45A226#004R	A	22	4	85	2.7	125	0.9	6	3.0	0.158	0.142	0.063
CA45B226#004R	B	22	4	85	2.7	125	0.9	6	2.5	0.184	0.166	0.074
CA45C226#004R	C	22	4	85	2.7	125	0.9	6	1.5	0.271	0.244	0.108
CA45A336#004R	A	33	4	85	2.7	125	1.3	8	3.0	0.158	0.142	0.063
CA45B336#004R	B	33	4	85	2.7	125	1.3	6	2.5	0.184	0.166	0.074
CA45C336#004R	C	33	4	85	2.7	125	1.3	6	1.5	0.271	0.244	0.108
CA45A476#004R	A	47	4	85	2.7	125	1.9	8	3.0	0.158	0.142	0.063
CA45B476#004R	B	47	4	85	2.7	125	1.9	6	2.5	0.184	0.166	0.074
CA45C476#004R	C	47	4	85	2.7	125	1.9	6	1.5	0.271	0.244	0.108
CA45A686#004R	A	68	4	85	2.7	125	2.7	14	2.5	0.173	0.156	0.069
CA45B686#004R	B	68	4	85	2.7	125	2.7	6	1.8	0.217	0.196	0.087
CA45C686#004R	C	68	4	85	2.7	125	2.7	6	1.5	0.271	0.244	0.108
CA45A107#004R	A	100	4	85	2.7	125	4.0	18	3.0	0.158	0.142	0.063
CA45B107#004R	B	100	4	85	2.7	125	4.0	14	2.0	0.206	0.186	0.082
CA45C107#004R	C	100	4	85	2.7	125	4.0	8	1.5	0.271	0.244	0.108
CA45B157#004R	B	150	4	85	2.7	125	6.0	16	1.8	0.217	0.196	0.087
CA45C157#004R	C	150	4	85	2.7	125	6.0	8	1.2	0.303	0.272	0.121
CA45D157#004R	D	150	4	85	2.7	125	6.0	8	0.8	0.433	0.390	0.173
CA45B227#004R	B	220	4	85	2.7	125	8.8	18	1.6	0.230	0.207	0.092
CA45C227#004R	C	220	4	85	2.7	125	8.8	10	1.2	0.303	0.272	0.121
CA45D227#004R	D	220	4	85	2.7	125	8.8	8	0.8	0.433	0.390	0.173
CA45C337#004R	C	330	4	85	2.7	125	13.0	10	1.2	0.303	0.272	0.121
CA45D337#004R	D	330	4	85	2.7	125	13.0	8	0.9	0.408	0.367	0.163
CA45E337#004R	E	330	4	85	2.7	125	13.0	12	0.8	0.454	0.409	0.182
CA45C477#004R	C	470	4	85	2.7	125	19.0	14	0.5	0.469	0.422	0.188
CA45D477#004R	D	470	4	85	2.7	125	19.0	10	0.4	0.612	0.551	0.245
CA45E477#004R	E	470	4	85	2.7	125	19.0	10	0.4	0.642	0.578	0.257
CA45D687#004R	D	680	4	85	2.7	125	27.0	12	0.5	0.548	0.493	0.219
CA45E687#004R	E	680	4	85	2.7	125	27.0	14	0.5	0.574	0.517	0.230
CA45D108#004R	D	1000	4	85	2.7	125	40.0	20	0.5	0.548	0.493	0.219
CA45E108#004R	E	1000	4	85	2.7	125	40.0	14	0.4	0.642	0.578	0.257
CA45V108#004R	V	1000	4	85	2.7	125	40.0	12	0.3	0.913	0.822	0.365
CA45E158#004R	E	1500	4	85	2.7	125	60.0	14	0.3	0.742	0.667	0.297
CA45V158#004R	V	1500	4	85	2.7	125	60.0	18	0.2	1.118	1.006	0.447
CA45A155#006R	A	1.5	6.3	85	4	125	0.5	6	3.0	0.158	0.142	0.063

CA45 Chip Tantalum Capacitors (SMD Tantalum Capacitors)

◆Table 4 Electrical Characteristics

Part Number	Case Code	Nominal Capacitance	Rated Voltage	Rated Temperature	Category Voltage	Category Temperature	Max DCL at +25°C	Max DF at +25°C 100Hz	Max ESR +25°C	Ripple Current (A) 100KHz Max		
										+25°C	+85°C	+125°C
		µF	V	°C	V	°C	µA	%	Ω			
CA45A225#006R	A	2.2	6.3	85	4	125	0.5	6	3.0	0.158	0.142	0.063
CA45A335#006R	A	3.3	6.3	85	4	125	0.5	6	3.0	0.158	0.142	0.063
CA45B335#006R	B	3.3	6.3	85	4	125	0.5	6	2.5	0.184	0.166	0.074
CA45A475#006R	A	4.7	6.3	85	4	125	0.5	6	3.0	0.158	0.142	0.063
CA45B475#006R	B	4.7	6.3	85	4	125	0.5	6	2.0	0.206	0.186	0.082
CA45A685#006R	A	6.8	6.3	85	4	125	0.5	6	2.5	0.173	0.156	0.069
CA45B685#006R	B	6.8	6.3	85	4	125	0.5	6	2.0	0.206	0.186	0.082
CA45A106#006R	A	10	6.3	85	4	125	0.6	6	3.0	0.158	0.142	0.063
CA45B106#006R	B	10	6.3	85	4	125	0.6	6	2.5	0.184	0.166	0.074
CA45C106#006R	C	10	6.3	85	4	125	0.6	6	1.5	0.271	0.244	0.108
CA45A156#006R	A	15	6.3	85	4	125	0.9	6	3.0	0.158	0.142	0.063
CA45B156#006R	B	15	6.3	85	4	125	0.9	6	2.5	0.184	0.166	0.074
CA45C156#006R	C	15	6.3	85	4	125	0.9	6	1.5	0.271	0.244	0.108
CA45A226#006R	A	22	6.3	85	4	125	1.4	8	3.0	0.158	0.142	0.063
CA45B226#006R	B	22	6.3	85	4	125	1.4	6	2.5	0.184	0.166	0.074
CA45C226#006R	C	22	6.3	85	4	125	1.4	6	1.5	0.271	0.244	0.108
CA45A336#006R	A	33	6.3	85	4	125	2.1	8	3.0	0.158	0.142	0.063
CA45B336#006R	B	33	6.3	85	4	125	2.1	6	2.5	0.184	0.166	0.074
CA45C336#006R	C	33	6.3	85	4	125	2.1	6	1.5	0.271	0.244	0.108
CA45A476#006R	A	47	6.3	85	4	125	3.0	10	3.0	0.158	0.142	0.063
CA45B476#006R	B	47	6.3	85	4	125	3.0	8	2.5	0.184	0.166	0.074
CA45C476#006R	C	47	6.3	85	4	125	3.0	6	1.5	0.271	0.244	0.108
CA45A686#006R	A	68	6.3	85	4	125	4.3	14	3.0	0.158	0.142	0.063
CA45B686#006R	B	68	6.3	85	4	125	4.3	10	1.5	0.238	0.214	0.095
CA45C686#006R	C	68	6.3	85	4	125	4.3	8	1.0	0.332	0.298	0.133
CA45A107#006R	A	100	6.3	85	4	125	10.0	26	3.0	0.158	0.142	0.063
CA45B107#006R	B	100	6.3	85	4	125	6.3	14	2.0	0.206	0.186	0.082
CA45C107#006R	C	100	6.3	85	4	125	6.3	8	1.5	0.271	0.244	0.108
CA45B157#006R	B	150	6.3	85	4	125	9.5	18	1.8	0.217	0.196	0.087
CA45C157#006R	C	150	6.3	85	4	125	9.5	10	1.2	0.303	0.272	0.121
CA45D157#006R	D	150	6.3	85	4	125	9.5	8	0.8	0.433	0.390	0.173
CA45B227#006R	B	220	6.3	85	4	125	14.0	18	1.6	0.230	0.207	0.092
CA45C227#006R	C	220	6.3	85	4	125	14.0	14	1.2	0.303	0.272	0.121
CA45D227#006R	D	220	6.3	85	4	125	14.0	8	0.8	0.433	0.390	0.173
CA45C337#006R	C	330	6.3	85	4	125	21.0	14	1.2	0.303	0.272	0.121
CA45D337#006R	D	330	6.3	85	4	125	21.0	8	0.9	0.408	0.367	0.163
CA45E337#006R	E	330	6.3	85	4	125	21.0	8	0.8	0.454	0.409	0.182
CA45D477#006R	D	470	6.3	85	4	125	30.0	14	0.4	0.612	0.551	0.245
CA45E477#006R	E	470	6.3	85	4	125	30.0	10	0.4	0.642	0.578	0.257
CA45V477#006R	V	470	6.3	85	4	125	30.0	10	0.4	0.791	0.712	0.316
CA45E687#006R	E	680	6.3	85	4	125	43.0	10	0.5	0.574	0.517	0.230
CA45V687#006R	V	680	6.3	85	4	125	43.0	10	0.4	0.791	0.712	0.316
CA45E108#006R	E	1000	6.3	85	4	125	63.0	14	0.4	0.642	0.578	0.257
CA45V108#006R	V	1000	6.3	85	4	125	63.0	14	0.3	0.913	0.822	0.365
CA45A105#010R	A	1	10	85	6.3	125	0.5	4	3.0	0.158	0.142	0.063
CA45B105#010R	B	1	10	85	6.3	125	0.5	4	2.5	0.184	0.166	0.074
CA45A155#010R	A	1.5	10	85	6.3	125	0.5	6	3.0	0.158	0.142	0.063
CA45A225#010R	A	2.2	10	85	6.3	125	0.5	6	3.0	0.158	0.142	0.063
CA45B225#010R	B	2.2	10	85	6.3	125	0.5	6	2.5	0.184	0.166	0.074
CA45A335#010R	A	3.3	10	85	6.3	125	0.5	6	3.0	0.158	0.142	0.063
CA45B335#010R	B	3.3	10	85	6.3	125	0.5	6	2.5	0.184	0.166	0.074
CA45A475#010R	A	4.7	10	85	6.3	125	0.5	6	3.0	0.158	0.142	0.063
CA45B475#010R	B	4.7	10	85	6.3	125	0.5	6	2.0	0.206	0.186	0.082
CA45A685#010R	A	6.8	10	85	6.3	125	0.7	6	2.5	0.173	0.156	0.069
CA45B685#010R	B	6.8	10	85	6.3	125	0.7	6	2.0	0.206	0.186	0.082
CA45C685#010R	C	6.8	10	85	6.3	125	0.7	6	1.5	0.271	0.244	0.108
CA45A106#010R	A	10	10	85	6.3	125	1.0	6	3.0	0.158	0.142	0.063
CA45B106#010R	B	10	10	85	6.3	125	1.0	6	2.5	0.184	0.166	0.074
CA45C106#010R	C	10	10	85	6.3	125	1.0	6	1.5	0.271	0.244	0.108
CA45A156#010R	A	15	10	85	6.3	125	1.5	6	3.0	0.158	0.142	0.063

CA45 Chip Tantalum Capacitors (SMD Tantalum Capacitors)

◆Table 4 Electrical Characteristics

Part Number	Case Code	Nominal Capacitance	Rated Voltage	Rated Temperature	Category Voltage	Category Temperature	Max DCL at +25°C	Max DF at +25°C 100Hz	Max ESR +25°C	Ripple Current (A) 100kHz Max		
										+25°C	+85°C	+125°C
		μF	V	°C	V	°C	μA	%	Ω			
CA45B156#010R	B	15	10	85	6.3	125	1.5	6	2.5	0.184	0.166	0.074
CA45C156#010R	C	15	10	85	6.3	125	1.5	6	1.5	0.271	0.244	0.108
CA45A226#010R	A	22	10	85	6.3	125	2.2	8	3.0	0.158	0.142	0.063
CA45B226#010R	B	22	10	85	6.3	125	2.2	6	2.5	0.184	0.166	0.074
CA45C226#010R	C	22	10	85	6.3	125	2.2	6	1.5	0.271	0.244	0.108
CA45A336#010R	A	33	10	85	6.3	125	3.3	14	3.0	0.158	0.142	0.063
CA45B336#010R	B	33	10	85	6.3	125	3.3	6	2.5	0.184	0.166	0.074
CA45C336#010R	C	33	10	85	6.3	125	3.3	6	1.5	0.271	0.244	0.108
CA45A476#010R	A	47	10	85	6.3	125	10.0	26	3.0	0.158	0.142	0.063
CA45B476#010R	B	47	10	85	6.3	125	4.7	8	1.8	0.206	0.186	0.082
CA45C476#010R	C	47	10	85	6.3	125	4.7	6	1.0	0.332	0.298	0.133
CA45A686#010R	A	68	10	85	6.3	125	6.8	26	2.5	0.173	0.156	0.069
CA45B686#010R	B	68	10	85	6.3	125	6.8	10	1.4	0.246	0.222	0.099
CA45C686#010R	C	68	10	85	6.3	125	6.8	6	1.5	0.271	0.244	0.108
CA45D686#010R	D	68	10	85	6.3	125	6.8	6	0.8	0.433	0.390	0.173
CA45A107#010R	A	100	10	85	6.3	125	10.0	26	3.0	0.158	0.142	0.063
CA45B107#010R	B	100	10	85	6.3	125	10.0	18	2.0	0.206	0.186	0.082
CA45C107#010R	C	100	10	85	6.3	125	10.0	8	1.5	0.271	0.244	0.108
CA45D107#010R	D	100	10	85	6.3	125	10.0	8	1.0	0.387	0.349	0.155
CA45C157#010R	C	150	10	85	6.3	125	15.0	10	1.2	0.303	0.272	0.121
CA45D157#010R	D	150	10	85	6.3	125	15.0	8	0.8	0.433	0.390	0.173
CA45E157#010R	E	150	10	85	6.3	125	15.0	8	0.6	0.524	0.472	0.210
CA45B227#010R	B	220	10	85	6.3	125	22.0	18	1.6	0.23	0.207	0.092
CA45C227#010R	C	220	10	85	6.3	125	22.0	14	1.2	0.303	0.272	0.121
CA45D227#010R	D	220	10	85	6.3	125	22.0	8	0.8	0.433	0.390	0.173
CA45E227#010R	E	220	10	85	6.3	125	22.0	8	0.6	0.524	0.472	0.210
CA45D337#010R	D	330	10	85	6.3	125	33.0	14	0.9	0.408	0.367	0.163
CA45E337#010R	E	330	10	85	6.3	125	33.0	8	0.8	0.454	0.409	0.182
CA45V337#010R	V	330	10	85	6.3	125	33.0	10	0.8	0.559	0.503	0.224
CA45E477#010R	E	470	10	85	6.3	125	47.0	14	0.4	0.642	0.578	0.257
CA45V477#010R	V	470	10	85	6.3	125	47.0	14	0.4	0.791	0.712	0.316
CA45E687#010R	E	680	10	85	6.3	125	68.0	14	0.5	0.574	0.517	0.230
CA45A105#016R	A	1	16	85	10	125	0.5	4	6.0	0.112	0.101	0.045
CA45B105#016R	B	1	16	85	10	125	0.5	4	2.5	0.184	0.166	0.074
CA45A155#016R	A	1.5	16	85	10	125	0.5	6	5.0	0.122	0.110	0.049
CA45B155#016R	B	1.5	16	85	10	125	0.5	6	2.5	0.184	0.166	0.074
CA45A225#016R	A	2.2	16	85	10	125	0.5	6	5.0	0.122	0.110	0.049
CA45B225#016R	B	2.2	16	85	10	125	0.5	6	2.5	0.184	0.166	0.074
CA45A335#016R	A	3.3	16	85	10	125	0.5	6	5.0	0.122	0.110	0.049
CA45B335#016R	B	3.3	16	85	10	125	0.5	6	2.5	0.184	0.166	0.074
CA45A475#016R	A	4.7	16	85	10	125	0.8	6	5.0	0.122	0.110	0.049
CA45B475#016R	B	4.7	16	85	10	125	0.8	6	3.0	0.168	0.151	0.067
CA45C475#016R	C	4.7	16	85	10	125	0.8	6	1.8	0.247	0.222	0.099
CA45A685#016R	A	6.8	16	85	10	125	1.1	6	4.0	0.137	0.123	0.055
CA45B685#016R	B	6.8	16	85	10	125	1.1	6	2.0	0.206	0.186	0.082
CA45C685#016R	C	6.8	16	85	10	125	1.1	6	1.5	0.271	0.244	0.108
CA45A106#016R	A	10	16	85	10	125	1.6	6	3.0	0.158	0.142	0.063
CA45B106#016R	B	10	16	85	10	125	1.6	6	2.5	0.184	0.166	0.074
CA45C106#016R	C	10	16	85	10	125	1.6	6	1.5	0.271	0.244	0.108
CA45A156#016R	A	15	16	85	10	125	2.4	6	3.0	0.158	0.142	0.063
CA45B156#016R	B	15	16	85	10	125	2.4	6	2.5	0.184	0.166	0.074
CA45C156#016R	C	15	16	85	10	125	2.4	6	1.5	0.271	0.244	0.108
CA45A226#016R	A	22	16	85	10	125	3.5	15	3.0	0.158	0.142	0.063
CA45B226#016R	B	22	16	85	10	125	3.5	6	2.3	0.184	0.166	0.074
CA45C226#016R	C	22	16	85	10	125	3.5	6	1.5	0.271	0.244	0.108
CA45B336#016R	B	33	16	85	10	125	5.3	8	2.1	0.184	0.166	0.074
CA45C336#016R	C	33	16	85	10	125	5.3	6	1.5	0.271	0.244	0.108
CA45D336#016R	D	33	16	85	10	125	5.3	6	1.0	0.387	0.349	0.155
CA45B476#016R	B	47	16	85	10	125	7.5	10	2.5	0.184	0.166	0.074
CA45C476#016R	C	47	16	85	10	125	7.5	6	1.5	0.271	0.244	0.108
CA45D476#016R	D	47	16	85	10	125	7.5	6	0.8	0.433	0.390	0.173
CA45E476#016R	E	47	16	85	10	125	7.5	6	0.6	0.524	0.472	0.210
CA45B686#016R	B	68	16	85	10	125	11.0	12	1.5	0.238	0.214	0.095
CA45C686#016R	C	68	16	85	10	125	11.0	6	1.5	0.271	0.244	0.108

CA45 Chip Tantalum Capacitors (SMD Tantalum Capacitors)

◆Table 4 Electrical Characteristics

Part Number	Case Code	Nominal Capacitance	Rated Voltage	Rated Temperature	Category Voltage	Category Temperature	Max DCL at +25°C	Max DF at +25°C 100Hz	Max ESR +25°C	Ripple Current (A) 100KHz Max		
										+25°C	+85°C	+125°C
		μF	V	°C	V	°C	μA	%	Ω			
CA45D686#016R	D	68	16	85	10	125	11.0	6	0.8	0.433	0.390	0.173
CA45E686#016R	E	68	16	85	10	125	11.0	6	0.7	0.486	0.437	0.194
CA45C107#016R	C	100	16	85	10	125	16.0	12	1.5	0.271	0.244	0.108
CA45D107#016R	D	100	16	85	10	125	16.0	8	0.7	0.387	0.349	0.155
CA45E107#016R	E	100	16	85	10	125	16.0	6	0.7	0.486	0.437	0.194
CA45D157#016R	D	150	16	85	10	125	24.0	8	0.8	0.433	0.390	0.173
CA45E157#016R	E	150	16	85	10	125	24.0	8	0.6	0.524	0.472	0.210
CA45V157#016R	V	150	16	85	10	125	24.0	8	0.4	0.791	0.712	0.316
CA45D227#016R	D	220	16	85	10	125	35.0	14	0.8	0.433	0.390	0.173
CA45E227#016R	E	220	16	85	10	125	35.0	10	0.6	0.524	0.472	0.210
CA45V227#016R	V	220	16	85	10	125	35.0	8	0.5	0.707	0.636	0.283
CA45E337#016R	E	330	16	85	10	125	53.0	14	0.8	0.454	0.409	0.182
CA45V337#016R	V	330	16	85	10	125	53.0	12	0.8	0.559	0.503	0.224
CA45E477#016R	E	470	16	85	10	125	75.0	16	0.4	0.642	0.578	0.257
CA45A474#020R	A	0.47	20	85	15	125	0.5	4	10.0	0.087	0.078	0.035
CA45A684#020R	A	0.68	20	85	15	125	0.5	4	6.0	0.112	0.101	0.045
CA45A105#020R	A	1	20	85	15	125	0.5	4	6.0	0.112	0.101	0.045
CA45B105#020R	B	1	20	85	15	125	0.5	4	2.5	0.184	0.166	0.074
CA45A155#020R	A	1.5	20	85	15	125	0.5	6	5.0	0.122	0.110	0.049
CA45B155#020R	B	1.5	20	85	15	125	0.5	6	2.5	0.184	0.166	0.074
CA45A225#020R	A	2.2	20	85	15	125	0.5	6	4.0	0.137	0.123	0.055
CA45B225#020R	B	2.2	20	85	15	125	0.5	6	2.5	0.184	0.166	0.074
CA45A335#020R	A	3.3	20	85	15	125	0.7	6	4.5	0.129	0.116	0.052
CA45B335#020R	B	3.3	20	85	15	125	0.7	6	2.5	0.184	0.166	0.074
CA45C335#020R	C	3.3	20	85	15	125	0.7	6	2.0	0.235	0.211	0.094
CA45A475#020R	A	4.7	20	85	15	125	0.9	6	3.0	0.158	0.142	0.063
CA45B475#020R	B	4.7	20	85	15	125	0.9	6	2.0	0.206	0.186	0.082
CA45C475#020R	C	4.7	20	85	15	125	0.9	6	1.8	0.247	0.222	0.099
CA45A685#020R	A	6.8	20	85	15	125	1.4	6	2.5	0.173	0.156	0.069
CA45B685#020R	B	6.8	20	85	15	125	1.4	6	2.0	0.206	0.186	0.082
CA45C685#020R	C	6.8	20	85	15	125	1.4	6	1.5	0.271	0.244	0.108
CA45A106#020R	A	10	20	85	15	125	2.0	8	3.0	0.158	0.142	0.063
CA45B106#020R	B	10	20	85	15	125	2.0	6	2.5	0.184	0.166	0.074
CA45C106#020R	C	10	20	85	15	125	2.0	6	1.5	0.271	0.244	0.108
CA45B156#020R	B	15	20	85	15	125	3.0	6	2.5	0.184	0.166	0.074
CA45C156#020R	C	15	20	85	15	125	3.0	6	1.5	0.271	0.244	0.108
CA45D156#020R	D	15	20	85	15	125	3.0	6	1.0	0.387	0.349	0.155
CA45B226#020R	B	22	20	85	15	125	4.4	7	2.5	0.184	0.166	0.074
CA45C226#020R	C	22	20	85	15	125	4.4	6	1.5	0.271	0.244	0.108
CA45D226#020R	D	22	20	85	15	125	4.4	6	0.8	0.433	0.390	0.173
CA45C336#020R	C	33	20	85	15	125	6.6	6	1.5	0.271	0.244	0.108
CA45D336#020R	D	33	20	85	15	125	6.6	6	1.0	0.387	0.349	0.155
CA45C476#020R	C	47	20	85	15	125	9.4	8	1.5	0.271	0.244	0.108
CA45D476#020R	D	47	20	85	15	125	9.4	6	0.8	0.433	0.390	0.173
CA45E476#020R	E	47	20	85	15	125	9.4	6	0.6	0.524	0.472	0.210
CA45C686#020R	C	68	20	85	15	125	14.0	8	1.5	0.271	0.244	0.108
CA45D686#020R	D	68	20	85	15	125	14.0	6	0.8	0.433	0.390	0.173
CA45E686#020R	E	68	20	85	15	125	14.0	6	0.7	0.486	0.437	0.194
CA45D107#020R	D	100	20	85	15	125	20.0	6	1.0	0.387	0.349	0.155
CA45E107#020R	E	100	20	85	15	125	20.0	6	0.7	0.486	0.437	0.194
CA45V107#020R	V	100	20	85	15	125	20.0	8	0.5	0.707	0.636	0.283
CA45D157#020R	D	150	20	85	15	125	30.0	10	0.8	0.433	0.390	0.173
CA45E157#020R	E	150	20	85	15	125	30.0	8	0.6	0.524	0.472	0.210
CA45V157#020R	V	150	20	85	15	125	30.0	8	0.4	0.791	0.712	0.316
CA45E227#020R	E	220	20	85	15	125	44.0	12	0.6	0.524	0.472	0.210
CA45V227#020R	V	220	20	85	15	125	44.0	12	0.5	0.707	0.636	0.283
CA45E337#020R	E	330	20	85	15	125	66.0	12	0.8	0.454	0.409	0.182
CA45V337#020R	V	330	20	85	15	125	66.0	12	0.8	0.559	0.503	0.224
CA45A334#025R	A	0.33	25	85	17	125	0.5	4	10	0.087	0.078	0.035
CA45A474#025R	A	0.47	25	85	17	125	0.5	4	10	0.087	0.078	0.035
CA45A684#025R	A	0.68	25	85	17	125	0.5	4	6.0	0.112	0.101	0.045
CA45B684#025R	B	0.68	25	85	17	125	0.5	4	4.0	0.146	0.131	0.058
CA45A105#025R	A	1	25	85	17	125	0.5	4	6.0	0.112	0.101	0.045

CA45 Chip Tantalum Capacitors (SMD Tantalum Capacitors)

◆Table 4 Electrical Characteristics

Part Number	Case Code	Nominal Capacitance	Rated Voltage	Rated Temperature	Category Voltage	Category Temperature	Max DCL at +25°C	Max DF at +25°C 100Hz	Max ESR +25°C	Ripple Current (A) 100KHz Max		
										+25°C	+85°C	+125°C
		µF	V	°C	V	°C	µA	%	Ω			
CA45B105#025R	B	1	25	85	17	125	0.5	4	2.5	0.184	0.166	0.074
CA45A155#025R	A	1.5	25	85	17	125	0.5	6	5.0	0.122	0.110	0.049
CA45B155#025R	B	1.5	25	85	17	125	0.5	6	2.5	0.184	0.166	0.074
CA45A225#025R	A	2.2	25	85	17	125	0.6	6	4.0	0.137	0.123	0.055
CA45B225#025R	B	2.2	25	85	17	125	0.6	6	2.5	0.184	0.166	0.074
CA45C225#025R	C	2.2	25	85	17	125	0.6	6	1.5	0.271	0.244	0.108
CA45A335#025R	A	3.3	25	85	17	125	0.8	6	3.0	0.158	0.142	0.063
CA45B335#025R	B	3.3	25	85	17	125	0.8	6	2.5	0.184	0.166	0.074
CA45C335#025R	C	3.3	25	85	17	125	0.8	6	2.0	0.235	0.211	0.094
CA45A475#025R	A	4.7	25	85	17	125	1.2	6	3.0	0.158	0.142	0.063
CA45B475#025R	B	4.7	25	85	17	125	1.2	6	2.0	0.206	0.186	0.082
CA45C475#025R	C	4.7	25	85	17	125	1.2	6	1.8	0.247	0.222	0.099
CA45B685#025R	B	6.8	25	85	17	125	1.7	6	2.0	0.206	0.186	0.082
CA45C685#025R	C	6.8	25	85	17	125	1.7	6	1.5	0.271	0.244	0.108
CA45D685#025R	D	6.8	25	85	17	125	1.7	6	1.2	0.354	0.318	0.141
CA45B106#025R	B	10	25	85	17	125	2.5	6	2.5	0.184	0.166	0.074
CA45C106#025R	C	10	25	85	17	125	2.5	6	1.5	0.271	0.244	0.108
CA45D106#025R	D	10	25	85	17	125	2.5	6	1.0	0.387	0.349	0.155
CA45B156#025R	B	15	25	85	17	125	3.8	8	2.5	0.184	0.166	0.074
CA45C156#025R	C	15	25	85	17	125	3.8	6	1.5	0.271	0.244	0.108
CA45D156#025R	D	15	25	85	17	125	3.8	6	1.0	0.387	0.349	0.155
CA45B226#025R	B	22	25	85	17	125	4.0	6	1.5	0.146	0.131	0.058
CA45C226#025R	C	22	25	85	17	125	5.5	6	1.5	0.271	0.244	0.108
CA45D226#025R	D	22	25	85	17	125	5.5	6	0.8	0.433	0.390	0.173
CA45D336#025R	D	33	25	85	17	125	8.3	6	1.0	0.387	0.349	0.155
CA45E336#025R	E	33	25	85	17	125	8.3	6	0.8	0.454	0.409	0.182
CA45D476#025R	D	47	25	85	17	125	12.0	6	0.8	0.433	0.390	0.173
CA45E476#025R	E	47	25	85	17	125	12.0	6	0.6	0.524	0.472	0.210
CA45D686#025R	D	68	25	85	17	125	17.0	8	0.8	0.433	0.390	0.173
CA45E686#025R	E	68	25	85	17	125	17.0	6	0.7	0.486	0.437	0.194
CA45V686#025R	V	68	25	85	17	125	17.0	6	0.5	0.707	0.636	0.283
CA45E107#025R	E	100	25	85	17	125	25.0	10	0.7	0.486	0.437	0.194
CA45V107#025R	V	100	25	85	17	125	25.0	8	0.5	0.707	0.636	0.283
CA45E157#025R	E	150	25	85	17	125	38.0	10	0.6	0.524	0.472	0.210
CA45V157#025R	V	150	25	85	17	125	38.0	10	0.4	0.791	0.712	0.316
CA45A154#035R	A	0.15	35	85	23	125	0.5	4	15	0.071	0.064	0.028
CA45A224#035R	A	0.22	35	85	23	125	0.5	4	15	0.071	0.064	0.028
CA45A334#035R	A	0.33	35	85	23	125	0.5	4	10	0.087	0.078	0.035
CA45A474#035R	A	0.47	35	85	23	125	0.5	4	10	0.087	0.078	0.035
CA45B474#035R	B	0.47	35	85	23	125	0.5	4	6.0	0.119	0.107	0.048
CA45A684#035R	A	0.68	35	85	23	125	0.5	4	6.0	0.112	0.101	0.045
CA45B684#035R	B	0.68	35	85	23	125	0.5	4	4.0	0.146	0.131	0.058
CA45A105#035R	A	1	35	85	23	125	0.5	4	6.0	0.112	0.101	0.045
CA45B105#035R	B	1	35	85	23	125	0.5	4	2.5	0.184	0.166	0.074
CA45A155#035R	A	1.5	35	85	23	125	0.5	6	6.0	0.112	0.101	0.045
CA45B155#035R	B	1.5	35	85	23	125	0.5	6	2.5	0.184	0.166	0.074
CA45C155#035R	C	1.5	35	85	23	125	0.5	6	1.5	0.271	0.244	0.108
CA45A225#035R	A	2.2	35	85	23	125	0.8	6	5.0	0.122	0.110	0.049
CA45B225#035R	B	2.2	35	85	23	125	0.8	6	2.5	0.184	0.166	0.074
CA45C225#035R	C	2.2	35	85	23	125	0.8	6	1.5	0.271	0.244	0.108
CA45B335#035R	B	3.3	35	85	23	125	1.2	6	2.5	0.184	0.166	0.074
CA45C335#035R	C	3.3	35	85	23	125	1.2	6	2.0	0.235	0.211	0.094
CA45B475#035R	B	4.7	35	85	23	125	1.6	6	2.0	0.206	0.186	0.082
CA45C475#035R	C	4.7	35	85	23	125	1.6	6	1.8	0.247	0.222	0.099
CA45D475#035R	D	4.7	35	85	23	125	1.6	6	1.2	0.354	0.318	0.141
CA45B685#035R	B	6.8	35	85	23	125	2.4	6	1.8	0.217	0.196	0.087
CA45C685#035R	C	6.8	35	85	23	125	2.4	6	1.5	0.271	0.244	0.108
CA45D685#035R	D	6.8	35	85	23	125	2.4	6	1.2	0.354	0.318	0.141
CA45C106#035R	C	10	35	85	23	125	3.5	6	1.5	0.271	0.244	0.108
CA45D106#035R	D	10	35	85	23	125	3.5	6	1.0	0.387	0.349	0.155
CA45E106#035R	E	10	35	85	23	125	3.5	6	0.8	0.454	0.409	0.182
CA45C156#035R	C	15	35	85	23	125	5.3	6	1.5	0.271	0.244	0.108
CA45D156#035R	D	15	35	85	23	125	5.3	6	1.0	0.387	0.349	0.155
CA45E156#035R	E	15	35	85	23	125	5.3	6	0.8	0.454	0.409	0.182
CA45C226#035R	C	22	35	85	23	125	7.7	6	1.5	0.271	0.244	0.108
CA45D226#035R	D	22	35	85	23	125	7.7	6	0.8	0.433	0.390	0.173
CA45E226#035R	E	22	35	85	23	125	7.7	6	0.5	0.574	0.517	0.230

CA45 Chip Tantalum Capacitors (SMD Tantalum Capacitors)

◆Table 4 Electrical Characteristics

Part Number	Case Code	Nominal Capacitance	Rated Voltage	Rated Temperature	Category Voltage	Category Temperature	Max DCL at +25°C	Max DF at +25°C 100Hz	Max ESR +25°C	Ripple Current (A) 100KHz Max		
										+25°C	+85°C	+125°C
CA45D336#035R	D	33	35	85	23	125	12.0	6	1.0	0.387	0.349	0.155
CA45E336#035R	E	33	35	85	23	125	12.0	6	0.8	0.454	0.409	0.182
CA45V336#035R	V	33	35	85	23	125	12.0	6	0.5	0.707	0.636	0.283
CA45D476#035R	D	47	35	85	23	125	17.0	10	0.8	0.433	0.390	0.173
CA45E476#035R	E	47	35	85	23	125	17.0	10	0.9	0.524	0.472	0.210
CA45V476#035R	V	47	35	85	23	125	17.0	8	0.4	0.791	0.712	0.316
CA45E686#035R	E	68	35	85	23	125	24.0	8	0.7	0.486	0.437	0.194
CA45V686#035R	V	68	35	85	23	125	24.0	6	0.5	0.707	0.636	0.283
CA45A154#050R	A	0.15	50	85	33	125	0.5	4	15	0.071	0.064	0.028
CA45B154#050R	B	0.15	50	85	33	125	0.5	4	14	0.078	0.070	0.031
CA45A224#050R	A	0.22	50	85	33	125	0.5	4	15	0.071	0.064	0.028
CA45B224#050R	B	0.22	50	85	33	125	0.5	4	14	0.078	0.070	0.031
CA45A334#050R	A	0.33	50	85	33	125	0.5	4	10	0.087	0.078	0.035
CA45B334#050R	B	0.33	50	85	33	125	0.5	4	8.0	0.103	0.093	0.041
CA45B474#050R	B	0.47	50	85	33	125	0.5	4	6.0	0.119	0.107	0.048
CA45C474#050R	C	0.47	50	85	33	125	0.5	4	3.0	0.191	0.172	0.077
CA45A684#050R	A	0.68	50	85	33	125	0.5	4	6.0	0.112	0.101	0.045
CA45B684#050R	B	0.68	50	85	33	125	0.5	4	4.0	0.146	0.131	0.058
CA45C684#050R	C	0.68	50	85	33	125	0.5	4	3.0	0.191	0.172	0.077
CA45A105#050R	A	1	50	85	33	125	0.5	4	6.0	0.112	0.101	0.045
CA45B105#050R	B	1	50	85	33	125	0.5	6	2.5	0.184	0.166	0.074
CA45C105#050R	C	1	50	85	33	125	0.5	4	2.0	0.235	0.211	0.094
CA45B155#050R	B	1.5	50	85	33	125	0.8	8	2.5	0.184	0.166	0.074
CA45C155#050R	C	1.5	50	85	33	125	0.8	6	1.5	0.271	0.244	0.108
CA45D155#050R	D	1.5	50	85	33	125	0.8	6	1.2	0.354	0.318	0.141
CA45B225#050R	B	2.2	50	85	33	125	1.1	8	2.5	0.184	0.166	0.074
CA45C225#050R	C	2.2	50	85	33	125	1.1	6	2.5	0.210	0.189	0.084
CA45D225#050R	D	2.2	50	85	33	125	1.1	6	2.5	0.245	0.220	0.098
CA45C335#050R	C	3.3	50	85	33	125	1.7	6	2.0	0.235	0.211	0.094
CA45D335#050R	D	3.3	50	85	33	125	1.7	6	1.5	0.316	0.285	0.126
CA45C475#050R	C	4.7	50	85	33	125	2.4	6	1.8	0.247	0.222	0.099
CA45D475#050R	D	4.7	50	85	33	125	2.4	6	1.2	0.354	0.318	0.141
CA45C685#050R	C	6.8	50	85	33	125	3.4	6	1.5	0.271	0.244	0.108
CA45D685#050R	D	6.8	50	85	33	125	3.4	6	1.2	0.354	0.318	0.141
CA45E685#050R	E	6.8	50	85	33	125	3.4	6	1.0	0.406	0.366	0.162
CA45D106#050R	D	10	50	85	33	125	5.0	6	1.0	0.387	0.349	0.155
CA45E106#050R	E	10	50	85	33	125	5.0	6	0.8	0.454	0.409	0.182
CA45V106#050R	V	10	50	85	33	125	5.0	6	0.7	0.598	0.538	0.239
CA45D156#050R	D	15	50	85	33	125	7.5	6	1.0	0.387	0.349	0.155
CA45E156#050R	E	15	50	85	33	125	7.5	6	0.8	0.454	0.409	0.182
CA45V156#050R	V	15	50	85	33	125	7.5	6	0.7	0.598	0.538	0.239
CA45E226#050R	E	22	50	85	33	125	11.0	8	0.5	0.574	0.517	0.230
CA45V226#050R	V	22	50	85	33	125	11.0	8	0.4	0.791	0.712	0.316

Important Note

1. Please do not use multimeter to test tantalum capacitors.
2. Capacitance and DF measured at :100Hz , $U_{-} = 2.2^{-.10}V$, $U_{\sim} = 1.0^{-.0.5}V$, Frequency = 100Hz. Test only applied to series equivalent circuit.
3. Please refer to derating voltage or category voltage if temperature > 85°C
4. The DCL parameter should be read after 5 minutes when it connected to the circuit.
5. For special requirement please consult to our sales.

Chip Tantalum Capacitor Selection and Application Notes

1. Selection & application: (CA45 is a series of products with manganese dioxide cathode, and CA55 is a series of products with polymer cathode.)

1.1 Load voltage temperature derating:

Product model	Cathode material	Conditions of Use	-55°C to 85°C	85°C to 125°C
CA45	MnO ₂	DC operating voltage derating according to operating temperature	U _R	80%U _R
		Maximum derating required for actual voltage	50%U _R	40%U _R
		Used in filter circuit	30%U _R	24%U _R
CA55	PEDOT	DC operating voltage derating according to operating temperature	U _R	80%U _R
		Maximum derating required for the actual voltage of products with U _R ≤ 10V used in the filter circuit	90%U _R	72%U _R
		Maximum derating required for actual voltage of U _R ≥ 10V products	80%U _R	64%U _R

When the operating ambient temperature is between 85°C and 125°C, derating is required to avoid the adverse effects of inrush current. Calculate the derated voltage relative to the rated voltage U_T using the following formula:

$$U_T = (U_R - U_C) * (T - 85) / 40$$

Note: U_R : Rated Voltage (V); U_C : Derated Voltage at 125°C (V); T: Ambient Temperature (°C)

1.2 Protection resistance:

Process status category	Process state description	Requirements and instructions
Product testing process	Steady state leakage current test and withstand voltage test.	A 1K Ω resistor should be connected in series between the positive pole of the power supply and the capacitor.
Application process of switching power supply circuit.	There is an instantaneous current passing through.	Resistance of at least 3 Ω / V in series.

1.3 Reverse voltage:

Ambient temperature	Maximum allowable reverse voltage
25°C	10%U _R or 1V, 10% U _R or 1V, whichever is smaller
85°C	5%U _R or 0.5V, 5% U _R or 0.5V, whichever is smaller
125°C	1%U _R or 0.1V, 1% U _R or 0.1V, whichever is smaller

1.3.1 Tantalum capacitors are polar capacitors. Reverse voltage is forbidden;

1.3.2 If reverse voltage is unavoidable, the applied time must be as short as possible, and should not exceed the corresponding voltage value in the table

1.3.3 Even if the reverse voltage and temperature meet the requirements in the table, tantalum capacitors can not withstand the reverse voltage continuously

1.4 Ability to withstand ripple voltage:

Formula	Explain	Notices
$E = Z \cdot I$	E: Ripple voltage Z: Impedance at specific frequency I: Ripple current	1. The power loss of ESR in capacitor does not exceed the appropriate value. 2. The sum of the peak values of DC voltage and ripple voltage shall not exceed the rated voltage. 3. The sum of negative peaks of DC voltage and ripple voltage shall not exceed the allowable reverse voltage.

1.5 Ability to withstand ripple current:

Formula	$I = \sqrt{\frac{P}{ESR}} \times K \times F$	Where: I = maximum allowable ripple current (A), P = power dissipation (mW), ESR = equivalent series resistance (mΩ), K = temperature derating factor, F = frequency derating factor
Explain	If ripple current is applied to the capacitor, Joule heat (power loss) will be generated inside the capacitor, which will affect the reliability of the capacitor. The maximum allowable ripple current (arms) of tantalum capacitor can be calculated according to the above formula	

Temperature	45°C	75°C	95°C	105°C	125°C	Frequency	10KHz	100 KHz	500KHz	1MHz
Derating factor K	1.00	0.95	0.85	0.50	0.40	Derating factor F	0.80	1.00	1.15	1.20

Case code	Size	P Power dissipation @+25°C (mW)	
		CA45 Series	CA55 Series
A	3216-16(±0.20)	75	100
B	3528-19(±0.20)	85	125
C	6032-25(±0.30)	110	175
H	7343-19(±0.30)	120	185
F	7260-19(±0.30)	130	200
D	7343-28(±0.30)	150	225
E	7343-41(±0.30)	165	250
V	7361-36(±0.30)	250	360
W	7361-41(±0.30)	285	420
X	7360-60(±0.30)	390	560

1.6 Suggestions on circuit redundancy design:

1.6.1 Failure mode:

CA45 type manganese dioxide tantalum capacitor will generate heat and burn when high current passes through. CA55 conductive polymer tantalum capacitor will generate heat when high current passes through, which may lead to cracking and failure of the capacitor. This depends on the over-current situation, time and other passive factors. Enough redundancy in the circuit design can ensure the high reliability of tantalum capacitor.

1.6.2 Hidden danger of passive factors:

Although the vast majority of failures of tantalum capacitors are caused by passive factors, safety hidden danger can not be ignored. Capacitor failure will increase the risk of equipment failure using the capacitor, so it is necessary to consider the failure protection design that the circuit can still work normally under the common capacitor failure mode in circuit design. Common failure modes are leakage current rise or short circuit, other failure modes are capacity attenuation, loss or impedance rise or open circuit. It is unsafe to use beyond the rated value of the data sheet.

1.7 Store:

1.7.1 Environmental requirements:

Vacuum storage is recommended. If non vacuum storage is adopted, attention should be paid to the temperature of 10 ~ 30 °C, humidity ≤ 60% RH, no acid, alkali and other corrosive gases.

1.7.2 Storage requirements:

The capacitor after unpacking the vacuum sealing bag is exposed to the air :
CA45 manganese tantalum dioxide capacitor: controlled according to MSL grade 1;
CA55 conductive polymer tantalum capacitor: controlled according to MSL Level 3 (CA55 product prevents moisture absorption).

1.7.3 Product moisture absorption treatment:

If the non vacuum storage period exceeds one year, it is recommended to dry the capacitor (125 °C Max / 4h Min) first, and then weld it after passing the test. If you don't have the right equipment to bake the products, you can contact us by telephone for assistance.

1.8 Welding:

1.8.1 Recommended welding conditions:

Reflow soldering SMT mounting is recommended.

1.8.1.1 Reflow soldering:

The peak setting temperature T_P of SMT should be ≤ 250 °C, and the holding time within the range of 0 °C ~ -5 °C of the peak temperature T_P should be ≤ 5 s.

1.8.1.2 Manual welding:

If manual welding is required under special circumstances, the power of electric iron should be ≤ 25 W, the temperature should be < 300 °C, and the welding time should be < 3 s. It is forbidden for the iron head to directly contact the product body, and the solder should be melted to make it contact with the capacitor pin for welding.

1.8.2 Precautions for reflow soldering:

The recommended reflow oven temperature setting for lead-free soldering is shown in the table below.

Equipment type	8 temperature zone		10 temperature zone	
	Upper	Lower	Upper	Lower
1 zone	120°C	120°C	100°C	100°C
2 zone	150°C	150°C	120°C	120°C
3 zone	160°C	160°C	150°C	150°C
4 zone	170°C	170°C	155°C	155°C
5 zone	200°C	200°C	160°C	160°C
6 zone	230°C	230°C	170°C	170°C
7 zone	250°C	250°C	200°C	200°C
8 zone	180°C	180°C	230°C	230°C
9 zone	/	/	250°C	250°C
10 zone	/	/	180°C	180°C

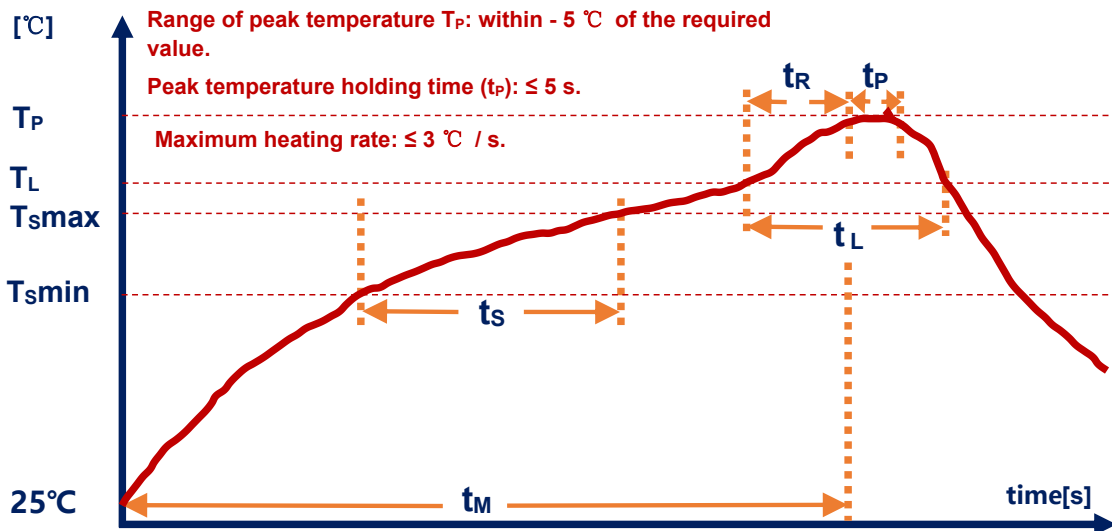

Solder type		Tin lead solder	Lead free solder
T_s Min	Minimum preheating temperature	100°C	150°C
T_s Max	Maximum preheating temperature	150°C	200°C
t_s	Preheating time	60~120s	60~120s
T_L ~ T_P	Heating rate	≤3°C/s	≤3°C/s
T_L	Melting point of solder paste	183°C	217°C
t_L	Melting time of solder paste	60~150s	60~150s
T_P	Peak temperature	220°C*/235°C**	245°C*/250°C**
t_P	Holding time of peak temperature (-5°C~0°C)	≤10s	≤3s* or 5s**
T_P ~ T_L	Cooling rate	≤6°C/s	≤6°C/s
t_M	Time from 25 ° C to peak temperature	≤6 min	≤8 min

Note: All temperatures are based on product size and measure the ambient temperature at 1cm height above the PCB board.

"" corresponds to a, B, C shells and "" "" corresponds to other shell numbers.d.

Note: CA45 is a chip solid electrolytic tantalum capacitor with manganese dioxide as the main cathode. Other derivative models such as CA45L, QCA45, CA45H, etc., share the same application requirements and precautions as CA45.
 CA55 is a chip solid electrolytic tantalum capacitor with conductive polymer as the main cathode. Other derivative models such as QCA55, CA55H, etc., share the same application requirements and precautions as CA55.