



SMT Power Inductors

Series/Type: B82464A4

The following products presented in this data sheet are being withdrawn.

Ordering Code	Substitute Product	Date of Withdrawal	Deadline Last Orders	Last Shipments
B82464A4684K000	No replacement	2025-07-18	2026-07-31	2027-01-31
B82464A4683K000	No replacement	2025-07-18	2026-07-31	2027-01-31
B82464A4682M000	No replacement	2025-07-18	2026-07-31	2027-01-31



Ordering Code	Substitute Product	Date of Withdrawal	Deadline Last Orders	Last Shipments
B82464A4474K000	No replacement	2025-07-18	2026-07-31	2027-01-31
B82464A4473K000	No replacement	2025-07-18	2026-07-31	2027-01-31
B82464A4472M000	No replacement	2025-07-18	2026-07-31	2027-01-31
B82464A4334K000	No replacement	2025-07-18	2026-07-31	2027-01-31
B82464A4333K000	No replacement	2025-07-18	2026-07-31	2027-01-31
B82464A4332M000	No replacement	2025-07-18	2026-07-31	2027-01-31
B82464A4224K000	No replacement	2025-07-18	2026-07-31	2027-01-31
B82464A4223K000	No replacement	2025-07-18	2026-07-31	2027-01-31
B82464A4222M000	No replacement	2025-07-18	2026-07-31	2027-01-31
B82464A4154K000	No replacement	2025-07-18	2026-07-31	2027-01-31
B82464A4153K000	No replacement	2025-07-18	2026-07-31	2027-01-31
B82464A4152M000	No replacement	2025-07-18	2026-07-31	2027-01-31
B82464A4105K000	No replacement	2025-07-18	2026-07-31	2027-01-31
B82464A4104K000	No replacement	2025-07-18	2026-07-31	2027-01-31
B82464A4103M000	No replacement	2025-07-18	2026-07-31	2027-01-31
B82464A4102M000	No replacement	2025-07-18	2026-07-31	2027-01-31

Please contact your nearest TDK sales office if you need support in selecting a suitable substitute. The addresses of our worldwide sales network are presented at www.tdk-electronics.tdk.com/sales.

SMD

Rated inductance 1 ... 1000 μ H
Rated current 0.33 ... 7 A

Construction

- Ferrite core
- Winding: enamel copper wire
- Winding welded to terminals

Features

- Temperature range up to +150 °C
- High rated current
- Low DC resistance
- Suitable for lead-free reflow soldering as referenced in JEDEC J-STD 020D
- Qualified to AEC-Q200
- RoHS-compatible

Applications

- Filtering of supply voltages
- Coupling, decoupling
- DC/DC converters
- Automotive electronics
- Industrial electronics

Terminals

- Base material CuFe2P
- Layer composition Ag, Sn (lead-free)
- Electro-plated

Marking

- Marking on component:
 Manufacturer, L value (nH, coded),
 L tolerance (coded), manufacturing date (YWWD),
 two last digits of work order
- Minimum data on reel:
 Manufacturer, ordering code, L value,
 quantity, date of packing

Delivery mode and packing unit

- 16-mm blister tape, wound on 330-mm \varnothing reel
- Packing unit: 750 pcs./reel

SMD

Dimensional drawing and layout recommendation

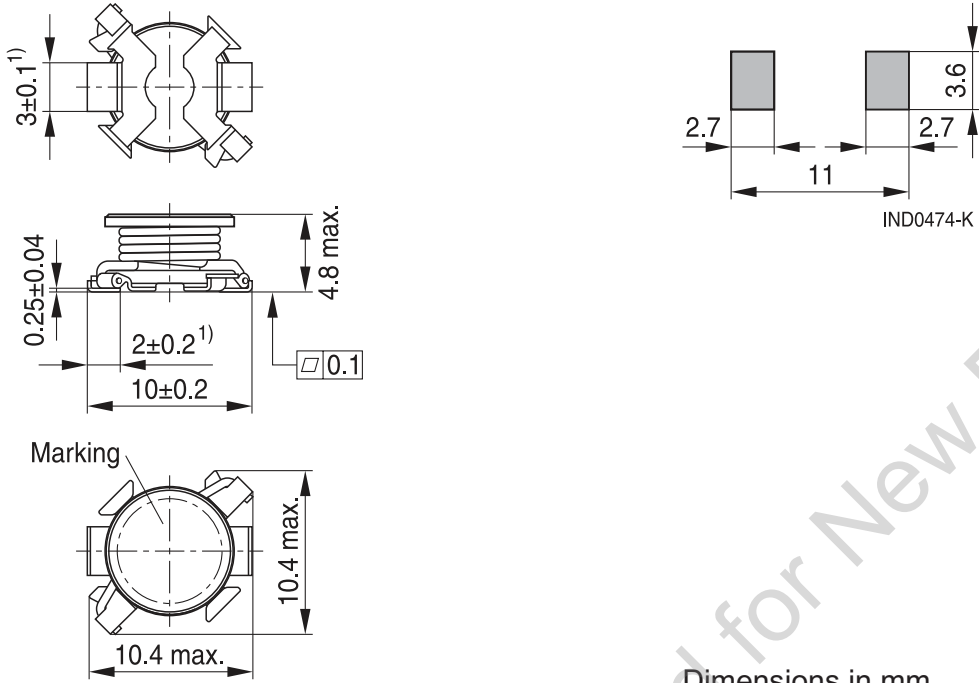

Dimensions in mm

1) Soldering area

IND0476-L-E

Taping and packing

Blister tape

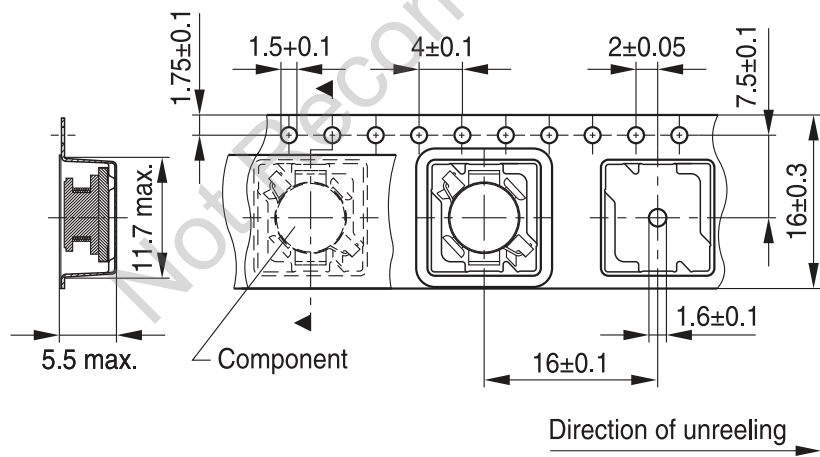

IND1536-X-E

Reel

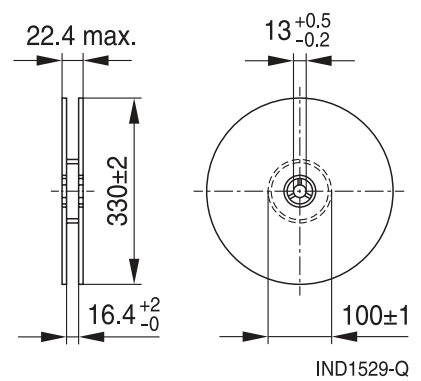

IND1529-Q

Dimensions in mm

SMD
Technical data and measuring conditions

Rated inductance L_R	Measured with impedance analyzer Agilent 4294A or equivalent at frequency f_L , 0.1 V, +20 °C
Operating temperature range	-55 ... + 150 °C
Rated current $I_{temp,typ}$	Max. permissible DC with temperature increase of ≤ 40 K at +85 °C
Saturation current I_{sat}	Max. permissible DC with inductance decrease $\Delta L/L_0$ of approx. 10%
DC resistance R_{max}	Measured at +20 °C
Solderability (lead-free)	Dip and look method Sn95.5Ag3.8Cu0.7: +(245 ±5) °C, (5 ±0.3) s Wetting of soldering area $\geq 90\%$ (based on IEC 60068-2-58)
Resistance to soldering heat	+260 °C, 40 s (as referenced in JEDEC J-STD 020D)
Climatic category	55/150/56 (to IEC 60068-1)
Storage conditions	Mounted: -55 °C ... +150 °C Packaged: -25 °C ... +40 °C, $\leq 75\%$ RH
Weight	Approx. 1.1 g

SMD
Characteristics and ordering codes

L_R μH	Tolerance	f_L MHz	$I_{\text{sat,typ}}$ A	$I_{\text{sat,min}}$ A	$I_{\text{temp,typ}}$ A	R_{max} Ω	R_{typ} Ω	Ordering code	
1.0	$\pm 20\% \triangleq \text{M}$	0.1	11.34	11.00	7.00	0.0090	0.0056	B82464A4102M000	
1.5		0.1	9.80	9.80	6.50	0.0100	0.0080	B82464A4152M000	
2.2		0.1	8.40	8.40	5.70	0.0120	0.0093	B82464A4222M000	
3.3		0.1	6.65	6.60	4.90	0.0150	0.0125	B82464A4332M000	
4.7		0.1	5.72	5.60	4.30	0.0180	0.0142	B82464A4472M000	
6.8		0.1	4.80	4.70	3.50	0.0270	0.0210	B82464A4682M000	
10		0.1	3.90	3.90	2.90	0.0380	0.0310	B82464A4103M000	
15		$\pm 10\% \triangleq \text{K}$	0.1	3.35	3.20	2.50	0.0460	0.0450	B82464A4153K000
22			0.1	2.60	2.60	2.10	0.0850	0.0650	B82464A4223K000
33	0.1		2.20	2.20	1.80	0.1000	0.0890	B82464A4333K000	
47	0.1		1.90	1.80	1.50	0.1400	0.1190	B82464A4473K000	
68	0.1		1.51	1.50	1.25	0.2000	0.1770	B82464A4683K000	
100	0.1		1.20	1.20	1.03	0.2800	0.2500	B82464A4104K000	
150	0.1		1.10	1.00	0.86	0.4000	0.3800	B82464A4154K000	
220	0.1		0.85	0.85	0.69	0.6100	0.5700	B82464A4224K000	
330	0.1		0.70	0.70	0.58	1.0000	0.8600	B82464A4334K000	
470	0.1		0.58	0.55	0.50	1.2700	1.1200	B82464A4474K000	
680	0.1		0.46	0.45	0.40	2.0000	1.6800	B82464A4684K000	
1000	0.1	0.38	0.38	0.33	3.0000	2.7000	B82464A4105K000		

SMD

Impedance $|Z|$ versus frequency f
 measured with impedance analyzer
 Agilent 4294A, typical values at +20 °C

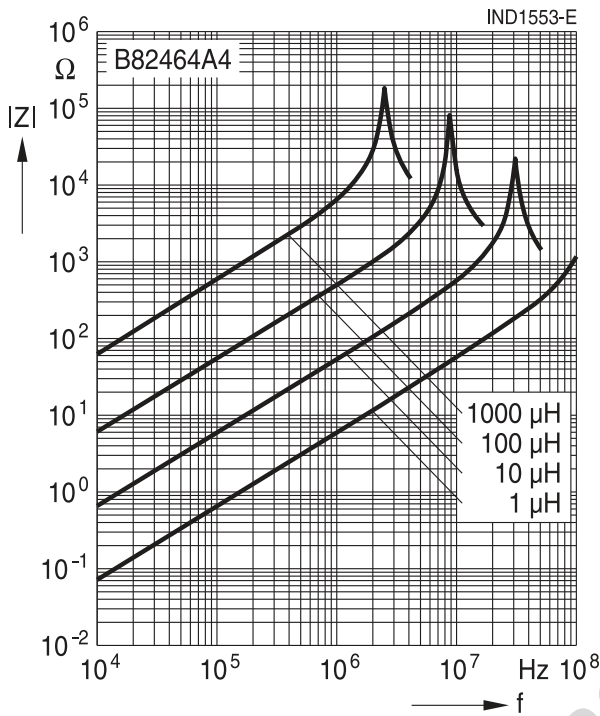

Inductance L versus DC load current I_{DC}
 measured with LCR meter Agilent 4285A,
 typical values at +20 °C

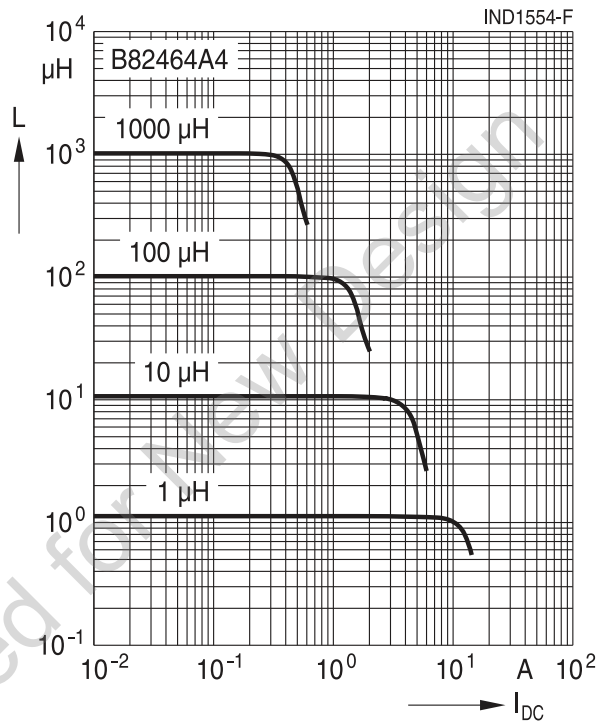

Current derating I_{op}/I_R
versus ambient temperature T_A
 (rated temperature $T_R = +85$ °C)

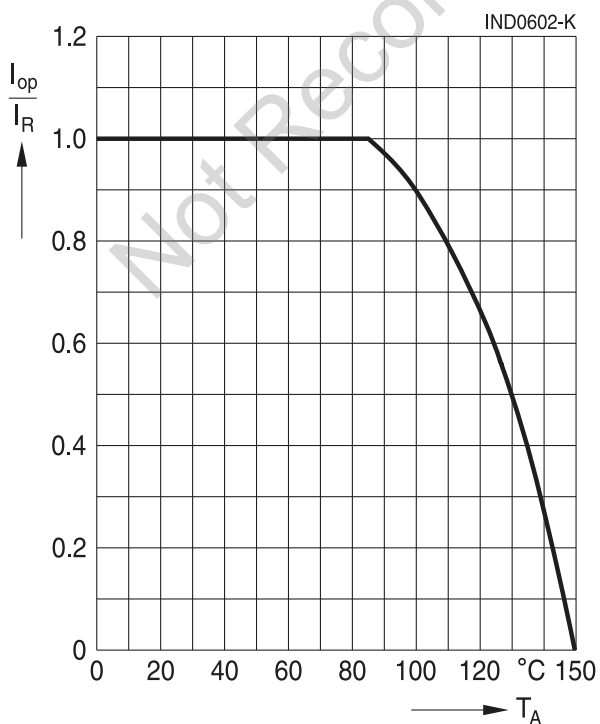

Cautions and warnings

- Please note the recommendations in our Inductors data book (latest edition), online catalogs and in the data sheets.
 - Particular attention should be paid to the derating curves, if given. Derating applies in the case the ambient temperature in application exceeds the rated temperature of the component.
 - Ensure the operation temperature of the component in application not to exceed the maximum specified value or the upper climatic category temperature.
 - The soldering conditions should also be observed. Temperatures quoted in relation to wave soldering refer to the pins only. Temperatures specified in relation to reflow soldering can also refer to the pins or terminals for products with larger thermal mass, as in such cases, the temperature difference to the top of the component is too big (e.g., high proportion of core within the component).
- If the components are to be washed varnished it is necessary to check whether the washing varnish agent that is used has a negative effect on the wire insulation, any plastics that are used, or on glued joints. It is possible for washing varnish agent residues to have a negative effect in the long-term on wire insulation.

Washing processes may damage the product due to the possible static or cyclic mechanical loads (e.g., ultrasonic cleaning). They may cause cracks to develop on the product and its parts, which might lead to reduced reliability or lifetime.
- The following points must be observed if the components are potted, sealed, or varnished in customer applications:
 - Many potting, sealing, or varnishing materials shrink as they harden. They therefore exert a pressure on the plastic housing or core. This pressure can have a deleterious effect on electrical properties, and in extreme cases can damage the core or plastic housing mechanically.
 - It is necessary to check whether the potting, sealing or varnishing materials used attack or destroy the wire insulation, plastics, or glue.
 - The effect of the potting, sealing, or varnishing materials may change the high-frequency behavior of the components.
- Magnetic core materials such as ferrites are sensitive to direct impact. This can cause the core material to flake or lead to breakage of the magnetic core material.
- Any type of tension or pressure on the product may result in damage and affect its functionality and reliability.
 - The products are only to be attached to fixings or mounting holes provided for this purpose in accordance with the data sheet.
 - If additional mechanical forces are applied to the component, e.g., application of gap pads, it is necessary to check whether they attack or destroy any part of the component.
 - It is not permitted for the product specified in the data sheet to assume a mechanical function in the final application.
- Inductance value can drop if external metallic or magnetic parts will be put close to the coil or into the air gap of the coil or core or magnetic material.
- Even for customer-specific products, conclusive validation of the component in the circuit can only be carried out by the customer.

Display of ordering codes for TDK Electronics products

The ordering code for one and the same product can be represented differently in data sheets, data books, other publications, on the company website, or in order-related documents such as shipping notes, order confirmations and product labels. **The varying representations of the ordering codes are due to different processes employed and do not affect the specifications of the respective products.**

Detailed information can be found on the Internet under www.tdk-electronics.tdk.com/orderingcodes.

Important notes

The following applies to all products named in this publication:

1. Some parts of this publication contain **statements about the suitability of our products for certain areas of application**. These statements are based on our knowledge of typical requirements that are often placed on our products in the areas of application concerned. We nevertheless expressly point out **that such statements cannot be regarded as binding statements about the suitability of our products for a particular customer application**. As a rule, we are either unfamiliar with individual customer applications or less familiar with them than the customers themselves. For these reasons, it is always ultimately incumbent on the customer to check and decide whether a product with the properties described in the product specification is suitable for use in a particular customer application.
2. We also point out that **in individual cases, a malfunction of electronic components or failure before the end of their usual service life cannot be completely ruled out in the current state of the art, even if they are operated as specified**. In customer applications requiring a very high level of operational safety and especially in customer applications in which the malfunction or failure of an electronic component could endanger human life or health (e.g. in accident prevention or life-saving systems), it must therefore be ensured by means of suitable design of the customer application or other action taken by the customer (e.g. installation of protective circuitry or redundancy) that no injury or damage is sustained by third parties in the event of malfunction or failure of an electronic component.
3. **The warnings, cautions and product-specific notes must be observed.**
4. In order to satisfy certain technical requirements, **some of the products described in this publication may contain substances subject to restrictions in certain jurisdictions (e.g. because they are classed as hazardous)**. Useful information on this will be found in our Material Data Sheets on the Internet (www.tdk-electronics.tdk.com/material). Should you have any more detailed questions, please contact our sales offices.
5. We constantly strive to improve our products. Consequently, **the products described in this publication may change from time to time**. The same is true of the corresponding product specifications. Please check therefore to what extent product descriptions and specifications contained in this publication are still applicable before or when you place an order.
We also **reserve the right to discontinue production and delivery of products**. Consequently, we cannot guarantee that all products named in this publication will always be available. The aforementioned does not apply in the case of individual agreements deviating from the foregoing for customer-specific products.
6. Unless otherwise agreed in individual contracts, **all orders are subject to our General Terms and Conditions of Supply**.

Important notes

7. **Our manufacturing sites serving the automotive business apply the IATF 16949 standard.**
The IATF certifications confirm our compliance with requirements regarding the quality management system in the automotive industry. Referring to customer requirements and customer specific requirements (“CSR”) TDK always has and will continue to have the policy of respecting individual agreements. Even if IATF 16949 may appear to support the acceptance of unilateral requirements, we hereby like to emphasize that **only requirements mutually agreed upon can and will be implemented in our Quality Management System.** For clarification purposes we like to point out that obligations from IATF 16949 shall only become legally binding if individually agreed upon.
8. The trade names EPCOS, CarXield, CeraCharge, CeraDiode, CeraLink, CeraPad, CeraPlas, CSMP, CTVS, DeltaCap, DigiSiMic, FilterCap, FormFit, InsuGate, LeaXield, MediPlas, MiniBlue, MiniCell, MKD, MKK, ModCap, MotorCap, PCC, PhaseCap, PhaseCube, PhaseMod, PhiCap, PiezoBrush, PlasmaBrush, PowerHap, PQSine, PQvar, SIFERRIT, SIFI, SIKOREL, SilverCap, SIMDAD, SiMic, SIMID, SineFormer, SIOV, SurfIND, ThermoFuse, WindCap, XieldCap are trademarks registered or pending in Europe and in other countries. Further information will be found on the Internet at www.tdk-electronics.tdk.com/trademarks

Release 2024-02

Not Recommended for New Design